

Starduster

MAGAZINE



Dedicated to the
ACTIVE Homebuilders

APRIL 1994



STOLP STARDUSTER CORPORATION 4301 Twining, Flabob Airport, Riverside, California 92509 / (909) 686-7943

APRIL "94"

COMMENTS FROM THE "PREZ"

By the time your'e reading this, hope you have your plans and reservations made for Sedona, Arizona - Not too early to plan for Oshkosh & Watoma, especially room reservations. John Peck is holding 10 rooms for "Starduster People" till end of May, then first come first served.

Am personally looking forward to the Dawn Patrol Breakfast Flight at Sedona - Maybe something similar at Watoma. Those of you that were at "Watoma" May remember "Dick Larson's Sunday Cookout - He & others are working hard to make our visit more pleasant & enjoyable than "93". I love it - Such a welcome change to previous years.

Will be at Sun & Fun 94 - My first visit - 9-10-11&12th. Will get to see Charles Wolff and Gene Hudkins airplanes for 1st time. Charles said he may fly to Sedona from Florida, his home.

We all know that when there has been an accident it gets our attention and we "tend" to our actions and airplanes - and "mend" them if necessary.

Flying wires have got a lot of attention and in Scotland there is an SA300 with 3 stretched or deformed wires - Please take a moment to check the wires that maintain the dimensions that we rely on for continued controlled flight.

Speaking of wires McWhyte has notified us of a 20% increase in wires - 25% end terminals.

We are all going to be pleased with the "Sedona" flyin attendance and again I ask - "Plan Ahead" - Have sufficient fuel for an alternate. Those that can't make it Friday could always meet the Dawn Patrol at Breakfast at Prescott Saturday - Am checking with Dick Lucas - See you there.

Later

BC
"B.C."

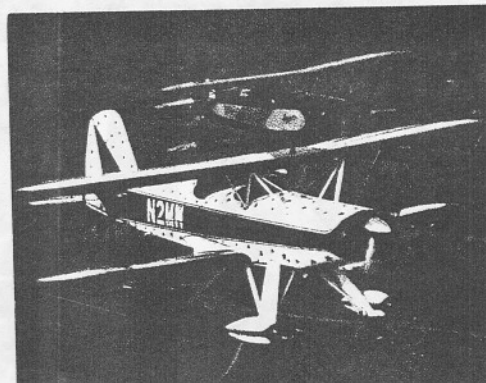

Stolp
Starduster
Corp.

APRIL 1994

THIS MAGAZINE USES MATERIAL SUBMITTED BY IT'S READERS. SOME ARTICLES OR STATEMENTS MAY NOT BE IN AGREEMENT WITH STOLP STARDUSTER CORPORATION OR IT'S EDITOR. INFORMATION AND ARTICLES USED ARE AT THE READERS RISK AND STARDUSTER MAGAZINE ASSUMES NO LIABILITY.

TABLE OF CONTENTS

PRESIDENTS COMMENTS	2
SUMMARY ACCIDENT UK	4
ODDS & ENDS FROM YOUR EDITOR	9
IAC AND THE STARDUSTER TOO	5
ADS SERVICE BULLETINS NPRMS	12
SAD NEWS - BOB HERENDEEN	14
STARDUSTER HISTORY - N700XP	16
TECH TIPS COCKPIT HEAT	19
LETTERS	20
HORROR STORY	31
MORE HORROR STORIES BY OSCAR BAYER	35
STARDUSTER 14TH ANNUAL OPEN HOUSE	36
STARDUSTER ACRODUSTER PARTS INCREASE	37
CLASSIFIEDS	39

We would like to thank all of this issues contributors and respond to one and all for some interesting information and photos.

FRONT COVER - Another Beautiful Starduster Too N135WL owned and built by Bill Lynch, 10422 W 57th st, Shanee, Kansas 66203. Bill and one of his friends flew this airplane to Anchorage, Alaska. Picture taken at Watoma, WI Aug '93.

BACK COVER - Nose, Tail and Inbetween Art. Left to right top, Max Bennet Buffalo, NY (N76GS), Jim Struthers Minneapolis, MN (N5393). Left to right bottom, Richard Hammond Tonawanda, NY (N236RH), and Bill Dunbar Rineyville, KY (N1518D).

SUBSCRIBE TO STARDUSTER MAGAZINE. PUBLISHED FOR PEOPLE BUILDING OUR AIRPLANES. TECHNICAL INFORMATION, NEWS & PICTURES. PUBLISHED FOUR TIME A YEAR. SUBSCRIPTION RATE IS \$12.00 PER YEAR, \$16.00 PER YEAR OVERSEAS MAILING (EXLUDING CANADA). SEND CHECKS TO STARDUSTER CORP., 4301 TWINING AVE., RIVERSIDE, CALIF. 92508

THE EDITOR IS ALWAYS LOOKING FOR TECHNICAL AND EDITORIAL CONTRIBUTIONS TO THIS MAGAZINE, WHICH IS DEDICATED TO THE HOME BUILDER AND SPORT AIRCRAFT ENTHUSIAST. PLEASE INCLUDE YOUR NAME, ADDRESS, TELEPHONE NUMBER AND YOUR "N" NUMBER ALONG WITH THE ARTICLE SUBMITTED.

AIR ACCIDENTS INVESTIGATION BRANCH
Department of Transport - United Kingdom

Accident to Stolp Starduster Too, G-BPOD, at Stancombe Farm, Askersewll, Dorset, UK, on 3 October 1993

The accident occurred as a result of a loss of control during a steep climb to about 400 feet agl after take-off, after the pilot applied some 30 degree of right bank.

Detailed examination of the aircraft wreckage revealed evidence that the two forward flying wires associated with the right upper wing had detached from their attachments to the forward spar as a result of the associated main attachment bolt having migrated forward out of the spar due to previous loss of friction nut. Evidence was also found which indicated that this nut may of unwound and the rear flying wire attachment may have become disconnected from the main bolt before this flight.

Aircraft Type & Registration:

Stolp Starduster Too, G-BPOD - (formerly N50SD U.S. Registry)

Date & Time (UTC):

3 October 1993 at about 1350 hrs

Location:

Stancombe Farm, Askerswell, Dorset, UK

On the morning of Sunday, 3 October 1993, the pilot strapped into the rear seat of G-BPOD and a colleague, who was also a qualified pilot, strapped into the front seat. The aircraft took off just before 1130 hrs and flew to Compton Abbas Airfield where it landed at 1145 hrs. The pilot refuelled the aircraft to full and took off again at 1230 hrs. The passenger handled the aircraft in the climb to 6,000 feet at which height both occupants, in turn, performed a series of aerobatic manoeuvres which included loops, barrel rolls and aileron rolls. They then returned to Stancombe Farm and landed.

The pilot then took another passenger for a short flight during which he performed some basic aerobatic maneauvears. On return to the airstrip, the pilot made an approach to the westerly runway; he used a sideslip technique wich allowed him to see the ground from the left side of the cockpit. However he was not satisfied with the approach because he was unable to stop the nose of the aircraft yawing to the left; he consequently elected to go-around. He attributed the problem to crosswind from the left and so, on the next approach, he sideslipped to the right and looked out of the right side of the cockpit. He found this more difficult but a successful landing was accomplished.

The passenger for the third flight was the owner of the airstrip; he was also a qualified pilot. The pilot again occupied the rear seat, and the passenger the front seat.

The aircraft took off shortly before 1350 hrs and the pilot held it low to gain airspeed; he then pulled into a steep climb to about 400 feet agl where he leveled off and started to turn right, initially with about 30 degree bank.

However the bank then increased rapidly and the aircraft entered a spin to the right from which it did not recover. Both occupants had five point harnesses, however the passenger was killed instantly as a result of the impact. The pilot was seriously injured; the injuries to his head were caused by contact with his instrument panel which had moved rearwards in the impact.

WEATHER

The weather in the area was fine, with good visibility.

EXAMINATION OF THE WRECKAGE

It was quickly established that although the aircraft had been structurally complete at impact, there had been pre-impact detachment of two out of the three flying wires attaching to the underside of the right hand upper mainplane.

The Stolp is of typical bi-plane construction in that the wings are effectively pin jointed to the fuselage and centre struts, the positive and negative g loads being carried respectively by the "flying" and "landing" wires.

There are three flying wires on each side of the fuselage, all attaching to the outboard upper mainplanes. The rear most is attached to the front and rear faces of the front spar. The flying and landing wires cross over in the interplane area and they are all lashed to a longitudinally oriented wooden construction. But they have steel plates bolted to the front and rear faces at the flying wire stainless steel strips, elliptical in section in order to minimize aerodynamic drag. The ends are terminated with turn barrels and fork end fittings which, at the outboard ends, are attached via nut, bolt and split pins, to channel (wire pull) section brackets. The latter are then bolted to the spars.

It was noted that the holes in the channel section brackets of the two front right hand side flying wires bore no evidence of distress, such as elongation, that could be expected as a result of impact forces with the bolt in position. The same was true of the holes in associated reinforcing plates. Such evidence indicated that the bolt had not been present at the time of impact. Neither the bolt nor its associated nut were recovered, despite a search of the accident site using metal detectors.

The paint had been worn away due to fretting between the front spar forward plate and the associated channel (wire pull) section bracket. Similar evidence was found on the underside bracket, and was indicated relative rotation, about the bolt, between the two components.

The hole in the spar plate (front face) had a raised lip on an arc of its circumference centered on a line whose radial orientation was aligned with the flying wire.

This feature was considered likely to have occurred as a result of tension in the front flying wire giving rise to a levering action as the bolt completed its forward migration out of the hole. Additional evidence of the forwards migration of the bolt was provided by a series of marks that conceivably could have been made by the bolt head, on the inner surface of the sheet alloy leading edge.

The front flying wires were removed from the left upper mainplane and the attachment components examined. Before removing the bolt and its associated stiffnut (which requires 7.5 ft lbs break-out torque), it was observed that 2 to 3 threads were visible aft of the end of the nut. The faces of the spar plates and the undersides of the channel section brackets showed evidence of rotational fretting, although to a slightly lesser extent than that observed on the right hand side. The bracket attached to the rear face of the spar displayed a bright, uncorroded area around the hole where it had been in contact with the face of the retaining nut. This was in stark contrast to the corresponding bracket from the failure area, which displayed evidence of long term corrosion, although it was possible to discern the contact area of the nut. This led to the conclusion that the nut had been missing from the right hand assembly for sometime.

The bolt removed from the left wing was 2 inches long and 1/4 inch diameter, with a drilled shank to accomodate a split pin. However, the relevant Stolp drawing calls up AN5-20A bolts for flying wire attachments. The "5" denotes the diameter in sixteenths of an inch; the "20" indicates the bolt length is 2 inches, and the "A" indicates that the shank should not be drilled for a split pin. Thus the bolts used on G-BPOD were of the correct length, but 1/16 inch undersize, and had drilled shanks. It was assumed that the missing nut and bolt were the same as those found on the left wing, as the holes in the spars were both 1/4 inch clearance holes; however, the holes in all the channel section brackets were 5/16 inch diameter.

The use of drilled bolts with stiffnuts is not generally recommended, as any "burrs" could cut away the elastic insert (which confers the high friction properties) within the nut. However during the removal of the nut from the left side flying wire attachment, it was noted that it retained its high friction characteristics until it was clear of the bolt threads. Stiffnuts are widely used on numerous aircraft types, and no airworthiness problems results through correct usage. However, where there is a risk of rotation in a bolted joint, it is normally safer to utilize a castellated nut and split pin.

Reference to the Stolp Starduster Corporation indicated that 5/16 inch diameter bolts have been used since 1968/9. Prior to this, two 1/4 inch bolts were used to attach the channel brackets to each of the spars. The change was made "...to allow rotation of the fitting (ie the bracket) to accomodate local flexing or dihedral."

HISTORY OF THE AIRCRAFT

The aircraft was constructed in 1975 and by the time it was imported to the United Kingdom in 1989, it had achieved 150 flying hours. The new owner was advised by the CAA and licensed engineers that an extensive rebuild was required before a UK Permit to Fly could be issued.

A Norfolk company eventually undertook this task, which took approximately nine months and involved regular visits by personnel from the CAA's General Aviation Section based at Gatwick, as well as the regional office at Stansted.

The aircraft had been received in a dismantled condition with the flying wires disconnected at the turnbarrels, ie leaving the fork end fittings and the channel section brackets attached to the spar plates. The rebuild did not involve replacing the fabric covering of the aircraft, although the records indicated that it was otherwise comprehensive. In the absence of access panels, knife cuts were made in the fabric to gain access to the structurally critical areas.

This included the flying wire attachments, and the person responsible for the rebuild project has stated that apart from visually checking that the nuts were in "safety", they were not touched. Patches were placed over the knife cuts rather than installing detachable access panels. (note; it is known that at least one UK registered aircraft, examined as part of this investigation, is fitted with such panels.)

The aircraft was test flown by a CAA pilot in October 1992, during which it was noted that the aircraft flew slightly "left wing-low" in the cruise, and that the right front flying wire tended to vibrate. This was corrected by tightening the wire and tends to suggest that all flying wires were attached at this time, although it does not necessarily confirm that the nut on the right hand side was in position.

The aircraft was last inspected at an annual inspection, in accordance with the Light Aircraft Maintenance Schedule (LAMS) in June of 1993, at 168 hours flying hours. The flying wire attachments were not inspected at that time since it was not a LAMS requirement. Indeed, in the absence of detachable access panels this could not have been achieved other than cutting holes in the fabric. At the time of the accident, the aircraft had achieved approximately 180 hours.

PROBABLE SEQUENCE OF EVENTS

The sequence of detachment of the two flying wires logically must have progressed from the nut coming off the bolt, the rear channel bracket dropping off the bolt tail, followed by the bolt migrating forward through the spar. When it finally emerged from the hole, the front wire would of course no longer be retained. Whilst the one remaining right flying wire that was attached to the rear spar clearly prevented a complete airborne structural collapse, it is reasonable to assume that there were significant changes in the wing torsional twist and dihedral angle on the right hand side.

It is probable that this caused the aircraft to enter the observed spin maneuver. The timetable for the above sequence could not be determined, although it seems probable that the bolt could have migrated through the spar in a short timescale, such as a duration of one flight. It follows that the rear wire could have been detached for sometime.

However this need not necessarily have been visible on a walk around inspection, as the inherent stiffness of the wire material, and the fact that it was linked, via the acorn, (javalins) to the other flying and landing wires would have tended to retain the wire in that position.

It is also possible that the rear wire could have remained attached for a time after the nut had fallen away, only becoming detached after partial migration of the bolt, or as a result of negative "g" or a hard landing. If the aircraft had been flown with only one forward flying wire being loaded, it is probable that small changes in wing twist and dihedral could occur. The fact that the aircraft reportedly flew left wing low at cruise before the accident may be indicative that such a condition existed.

The reason for the nut detachment could not be determined. It is possible that flying wire vibration or structural flexing, resulted in the channel (wire pull) bracket unwinding the nut via "ratchet" action. However, the corrosion evident around the hole in the bracket indicated that there were no significant contact with the face of the nut for sometime.

As a result of this accident, the following Safety Recommendations have been made to the CAA:

93-70 It is recommended that the CAA should require that all flying wire attachment bolts on UK registered Stolp Starduster aircraft be replaced with correct size bolts and, since limited rotation of the flying wire/spar attachments occurs, castellated nuts and split pins should be required.

93-71 It is recommended that the LAMS require all UK registered Stolp Starduster aircraft to be fitted with detachable access panels in appropriate position on the wings to enable the associated flying wire attachments to be properly inspected for security.

93-72 It is recommended that the LAMS requirement (in Section 7) to "Remove sufficient detachable panels and covers to inspect the internal structure of ...mainplanes..." at 150 hour and annual checks, be amended to include the removal of sufficient fabric to enable adequate inspection of these areas.

EDITOR'S NOTE: Regarding UK Accident

It is interesting to read this report, in that extensive rebuild was required prior to it being flown in the UK. And that this extensive rebuild did not require the aircraft to be recovered. It is also very interesting that with all this detailed inspection and rebuild, over a nine month period, that this problem was not noted. Further it is hard for me to believe that flexing or ratcheting would result in the elastic stop nut being unscrewed. A contributing factor could be the incorrect use of 1/4 " bolts mated to the 5/16" hole in the wire pull, which does give some credit to the ratcheting theory.

However if you subscribe to that, how about the left hand side which was intact and tight. This also was assembled with the incorrect 1/4" bolt. Actually it is a tribute to the extra safety margin built into the Stolp design. In that it was flown almost 200 hours with the incorrect bolts installed and if ratcheting was indeed the culprit, what about all the other Starduster aircraft flying. I know of several Stardusters that have accumulated well over 1500 hours, of which a large percentage was performing aerobatics.

ODDS & ENDS FROM YOUR EDITOR

This is my fourth year as editor of Starduster Magazine, and it is the first time I have received so many letters from new and old subscribers, offering their appreciation for the effort, quality, and content of the magazine. I am pleased they chose to write, as it makes doing the magazine so much more rewarding. Furthermore I sincerely appreciate the input as well as the articles that you readers have supplied me. For without you, Starduster Magazine would not exist.

We now have over 300 subscribers with a good 30% growth per year. Again thanks and I welcome your comments.

As pilots and aircraft owners, how special do we want to be. Talk about minorities, I believe we pilots are one of the smallest minorities in existence. Reference the recent article in the second January issue of General Aviation News & Flyer by Darryl Phillips. Where we as pilots, mechanics, and owners are subject to fines, suspension and revocation of our licenses medicals, and of which the amount, severity and frequency can be applied arbitrarily. We also have little recourse under the present law, help from the legal profession or the NTSB.

Look at what recently happened to Bob Hoover. He of course had some very influential help in high places. But apparently that was not enough as the NTSB has over ruled its own administrative law judge who earlier after watching Hoover perform his act, had ordered his medical to be returned. So unless he appeals and is successful. Bob Hoover's days as an airshow performer are over.

This leads me to the conclusion, more than ever, fly safe and responsible. Do not attempt low altitude acro. Do not buzz your neighbors house. Do not push the weather. Keep fuel in your airplane and at the utmost maintain your aircraft and piloting skills. If you do these things, the chance of you being suspended, fined or requiring an aviation attorney is greatly diminished.

Also you readers have no doubt heard about the proposal to privatize the nations air traffic control system, and turn it over to a government owned corporation. Most all general aviation users of the system are opposed to it. The airlines of course are for it. We as pilots and aircraft owners are painfully aware of the cost and problems currently facing us, with the general aviation fleet growing older, pilot population, as well as aircraft ownership declining and no hope of product liability legislation being implemented, the future does not look good.

We could be faced with this ominous problem. Reference the March 1994 AOPA article written by Phil Boyer. The topic was about paying for ATC assistance during a typical trip from Maryland to Florida, with weather briefing, flight plan, mostly VFR, IFR release, tower center and approach control contact, and under the current proposal which claims to be low for general aviation, could cost about \$100.00 for the privilege to talk with them and use the system.

If this is adopted, it could certainly mean the end of private flying as we know it. I, over the last several years have been advocating that we use only essential services, those that are incidental to the flight (I.E) Weather all the time and ATC only in congested airspace.

We as biplane pilots could get along very nicely with out much in the way of ATC services. The problem as I see it is, if we were required by F.A.R.S to use the system and subsequently are charged for each ATC contact, this in my opinion would increase substantially the cost to operate light aircraft. The result would be fewer and fewer aircraft. Which would raise costs even higher.

Everyone always talks about the good old days, and I certainly hope that we do not look back on this and the prior years as the good old days.

You should do everything in your power to stop this proposal. I encourage you, just like Phil Boyer the AOPA President has done, to write your congressman expressing your adamant disapproval of the ATC privatization proposal.

On to more pleasant things. We would certainly like to congratulate Gene Hudkins for his recent Grand Champion Award at the Southeastern Regional Fly-in. It seems like everytime he takes his Starduster to a fly-in, he comes home with an award, and believe me he deserves it, as I can attest to having seen this airplane in person at Oshkosh in 1993. Good job Gene and N88H.

We would also like to congratulate Bill Dunbar for his award Best of Show at the recent Salem Indiana Fly-in. This also is a well built and very pretty airplane. Again I can say this first hand as we were parked together for several days at Oshkosh. Well done and fly safe.

D.C.B. Editor

U.K. ACCIDENT CONTINUED FROM PAGE 8

My personal opinion is that prior to covering, by the original builder, all the wire pulls (channel brackets), along with the terminal ends that were installed in the wings were probably finger tight, and during the process of assembly and tightening, that one was missed. This in its self certainly makes a case for having more than one person inspect the aircraft prior to covering and assembly. Also the person doing the inspection needs to be famillure with the type of aircraft.

The accident investigation in the United Kingdom, that was performed on this aircraft was very extensive and detailed, much more so than in this country, and the investigators are to be commended.

D.C.B. Editor

INTERNATIONAL AEROBATIC CLUB

Bill Clouse recently received a letter from the I.A.C. encouraging owners of Stardusters to participate in sanctioned events with their airplanes. Their goal is to increase participation as well as membership.

I have mixed emotions as to how I should respond, not being much of an aerobatic enthusiast leaves me at a disadvantage. I do however believe that we should be safe and proficient with our airplanes. And to this end, loops, slow rolls, and spins should be part of that goal. These maneuvers should of course be performed at altitude with parachutes and with an instructor who is current and familiar with your type of aircraft.

In the past, at these meets, we who have owned Stardusters have been looked down on because Stardusters were (not) considered to be much of an aerobatic machine like the Pitts. Many Starduster owners have taken considerable heat from the Pitts drivers over this perceived inequity during local I.A.C. meets.

The Pitts drivers are starting to feel the same sort of thing themselves, as the new single wing Stevens acro, Lazer and European Extra 230, 300 types have become more popular.

Lou Stolp, designer of the Starduster Too, has never advocated aerobatics with the Starduster Too, then or now. As it was intended to be only a weekend sport biplane. He was however smart enough to make it plenty strong (6+ and 6-Gs), as he also knew that many pilots would do acro with or without his blessing.

Lou has some pretty strong arguments to support his position, and this opinion was formed long before liability was the issue it is today. He had told me many years ago, that all aerobatic pilots, airshow or competition, that he had known over the years were all gone. With the exception of Art Scholl, and of course now Art is gone.

I do however believe the Starduster Too is a capable aerobatic machine, and with the right airplane and pilot, it is also capable of winning in Sportsman and Intermediate. Ask Al Pietch, Peter Cavallo or Steve Beaver, all of these pilots have done well in competition. Starduster Corporation now offers the X wing for the Starduster Too. It is a symmetrical airfoil using much of the Acroduster plan form, with forward mounted slave struts, but retaining the size and shape of the original Starduster wing.

Your editor has every intention of becoming more proficient with his Starduster Too N96576. I need to get my inverted oil system installed. As Steve Wolf offered to fly my airplane to evaluate what I should and should not attempt to do with it. Also if John Helton ever gets up here in the northwest, he also said he would be happy to help me accomplish this task.

So if you decide to explore your envelope please do so at altitude, and if you have the interest, by all means get involved with your local I.A.C. chapter and take advantage of their experience. Besides, now the Pitts drivers just might be a little more sympathetic to you.

D.C.B. Editor

AD's SERVICE BULLETINS, NPRM's
And Other Maintenance Information

Dyed Diesel Fuel Looks Like Avgas

Aviation officials across the country have issued an urgent warning to pilots who burn avgas in their airplanes: **BE CAREFUL NOT TO FILL YOUR TANKS WITH DIESEL FUEL!** Diesel fuel, colored with blue-green dye can look like 100-octane avgas, which is also colored with a red dye.

Compounding the problem: Diesel colored blue-green dye sometimes comes out green, making it look like 100/130 avgas, which is also dyed green. When you can not use color as a clue, the best way to tell the difference between avgas and diesel is by smell and feel. Diesel rubbed between thumb and fingers has a greasy feel when compared to gasoline.

"I consider this potential hazard to be critical to aviation safety," said Charles Huettner, the FAA's acting associate administrator for aviation safety.

When the agency was informed that adding the dye to jet fuel would make it look like 100-octane avgas, "We exempted jet fuel from regulation," said Mary Smith, director of the Field Operations and Support Division of EPA's Office at Mobile Sources.

Even if the program was halted immediately, however, aviation officials warned "massive quantities" of dyed diesel fuel have already entered the distribution system. While the dye requirement did not become effective until January 1st, refiners have been adding it to diesel since October 1, 1993.

"We wanted to make sure people don't end up killing themselves, or damaging their engines, before we get this resolved," said the AOPA's Doug MacNair.

The new regulations require that high sulfur diesel, and diesel not subject to fuel taxes, be dyed green-blue. Meanwhile the IRS alone is requiring that low-sulfur fuel that is tax-exempt, such as that used to power a farmer's pickup truck, be dyed red.

The danger posed by dyed diesel fuel is getting special attention in Alaska, where it is common to see tanks and drums of heating oil and diesel fuel sitting beside identical tanks and drums of 100LL avgas.

The FAA's National Flight Data Center in Washington D.C., has issued a NOTAM warning pilots, air carriers and fuel vendors across the country of the safety hazard posed by dyed diesel.

Narco Service Bulletin ELT-14

The FAA has received 42 reports since January 1st of NARCO ELT-10 emergency locator transmitters failing during G-force aviation tests.

It was noted by many of the submitters that the problem could have been prevented if owners had complied with Narco Service Bulletin ELT-14, issued April 21, 1986, which suggest periodic inspection and recertification.

Watch for the service bulletin to become airworthiness directive in the coming months. The average age of an ELT-10 is now approximately 20 years.

NPRM 93-ANE-48

NPRM 93-ANE-48; Textron Lycoming Reciprocating Engines. Would supersede an existing AD that requires replacement of sintered iron impellers in oil pumps. Would also require replacement of aluminum impellers. Comments due by March 4, 1994.

NPRM 93-ANE; Precision Airmotive Products Model HA-6 series carburetor. Would require modification of HA-6 carbs not equipped with mixture control retainer clips.

Air Worthiness Directive 94-01-03

Airworthiness Directive 94-01-03; Teledyne Continental Motors; Final rule, Docket No. 93-ANE-44, Amendment 39-8785. Applies to (formerly Bendix) model S-20, S-200, S-600 and S-1200 magnetos. Supersedes existing AD requiring replacement of certain Bendix ignition coils and rotating magnets that have accumulated 2,000 hours of time in service. Copies of the airworthiness directives or NPRM's are available from EAA's Boeing Library, attention Dennis Park, P.O. Box 3086, Oshkosh, WI 54903-3086.

MAINTENANCE INFORMATION

Starduster Inverted Fuel System Flop Tubes

It has been brought to my attention that a Starduster Too performing aerobatics during an airshow suffered engine failure. The cause was found to be a broken flop tube in the inverted sump. It had broken off resulting in fuel starvation and an unplanned off airport landing. The tube was found to be in poor condition due to deterioration. This was one of the first Starduster Toos to fly, about 1969 or well over 20 years of service. It is our recommendation that during the next annual inspection that the flop tube be removed, inspected and replaced if necessary. And if your airplane is an old one, 5 years or more, should probably be replaced. The information is presented in the interest of safety, and all owners and operators should comply immediately. Especially if your airplane has only one outlet from the fuel tank to carburetor and it is supplied by the flop tube.

D.C.B. Editor

SAD NEWS

Bob Herendeens Last Flight

1928 - 1993

I am sure that most of you are aware that Bob Herendeen was fatally injured when his Christian Eagle crashed during level flight into rising terrain. He was attempting to take pictures of a house he owned prior to its sale.

I will not write of his accomplishments as the information on the next page will certainly take care of that. But what I will talk about is the kind of person that Bob was. He truly was the kind of person that aviation needs. He always had time for everyone. When he talked to you, the friendship was instant and lasting.

I had known Bob since the late sixties, when he and Morgan (Bud) Schrack use to come to Fla-Bob. We would almost always get a free airshow, with Bob in his Pitts and Morgan in his Starduster Too.

Morgan was a captain for TWA and Bob was his first officer during that time. Bob in my opinion was one of the best Pitts aerobatic pilots ever. Only Sean Tucker has been able to do more with the Pitts. But I think the airplane with its modifications have allowed Sean to do the incredible things he does.

The one maneauver during the airshow season that Bob and Jacque flew together which is not mentioned in the article was very hard to do. Jacque, in her Eagle, would come across the field at about 500 feet and Bob would do multupal slow rolls around her. I had talked to a young Navy A-6 pilot from Widby Island NAS during the NW EAA Fly-in at Arlington, Washington, when Bob & Jacque did this routine.

He told me what great fun it had been to do slow rolls around the target tugs, until one of his fellow pilots collided with it. His point was, that it was very difficult to do more than one roll, and keep the same distance from the tug. But Bob & Jacque did this routinely for several airshow seasons.

I really thought that if he did get killed, it would be in his Glasair III, with it coming apart. But Bob had great faith in the airplane as he built one for himself, and flew it during this last airshow season.

I had only talked with him a few times over the last several years, and so many years ago when researching the book Starduster History. He was kind enough to send pictures of Morgans Starduster and Acroduster Too. He was single for many years only getting married to Jacque about the time he retired from TWA. They both loved aerobatics, so it was natural that they got together. He really was a gentleman to aerobatics, aviation, and to me. It was certainly a pleasure to have known him.

D.C.B. Editor

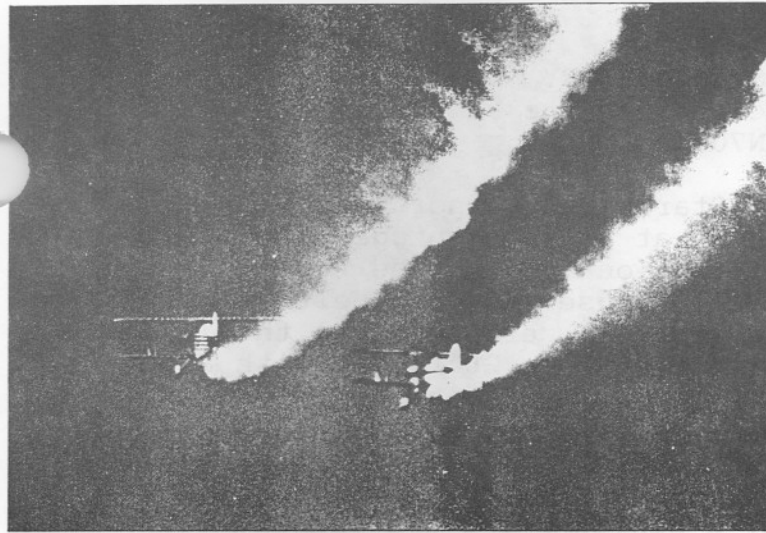

**BOB AND JACQUE HERENDEEN
PERFORM AN EXCITING COMBINATION
DUAL AND SOLO AEROBATIC ROUTINE,
JACQUE IN HER CHRISTEN EAGLE AND
BOB IN HIS PITTS SPECIAL**

Jacque is a former competition pilot offering a combination of precision, grace, beauty and lyrical style with her Eagle Aerobatics. Her performance includes tail slides, snap rolls, hammerhead turns, humpty bumps, point rolls, and other exciting maneuvers. During the formation flying Jacque flies lead in her Christen Eagle II, while Bob flies wingman. She has over 1600 hours, most of which is in a Decathlon, Pitts, T-18 and Eagle.

Bob is a two-time U.S. National Unlimited Aerobatic Champion, member of the U.S. Aerobatic Team from 1965 thru 1971, 1980 and 1982, and winner of Silver and Bronze Medals in World Competition. His flying career includes 5 years as a U.S. Air Force fighter pilot, 30 years as an airline pilot, and over 22 years of Air Show experience. In his 19000+ flight hours he has flown over 80 different models of aircraft from J-3 Cubs to Lockheed L-1011's and holds certificates for Air Transport Pilot, Instructor, and A & P Mechanic. Bob has flown aerobatics since his first solo flight during which he did Loops and Spins! His Air Show performances include such crowd-pleasing maneuvers as the Triple Snap Roll on Take-off, Torque Rolls, the incredible tumbling Lomcevak, and the Mile Long Flat Inverted Spin (the Corkscrew In The Sky).

The Herendeens bring a blend of experienced dedication, enthusiastic freshness and skill to their performances.

**PITTS SPECIAL S-1S
SPECIFICATIONS**

Engine	180 H.P. Lycoming
Length	14 ft. 6 in.
Wingspan	17 ft. 4 in.
Empty Weight	785 lbs.
Fuel Capacity	20 gal.
Top Speed	175 MPH
Cruise Speed	138 MPH
Landing Speed	65 MPH
Structural Limits	+9G -9G

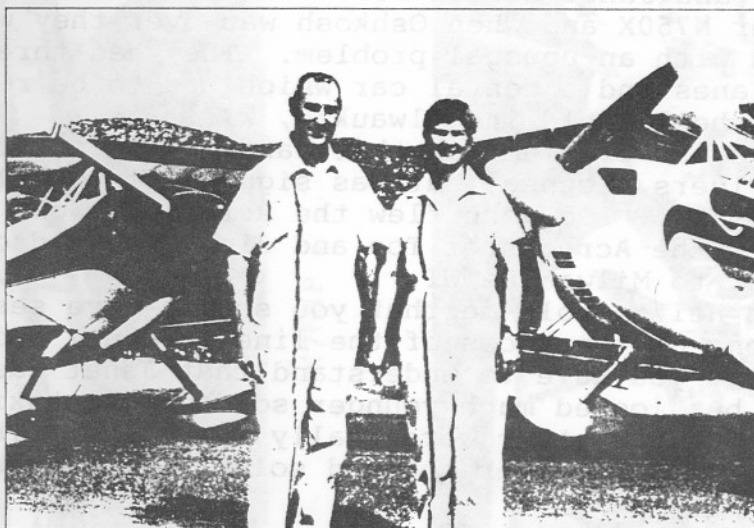

**CHRISTEN EAGLE II
SPECIFICATIONS**

Engine	200 H.P. Lycoming
Length	17 ft. 9 in.
Wingspan	19 ft. 11 in.
Empty Weight	1050 lbs.
Fuel Capacity	25 gal.
Top Speed	184 MPH
Cruise Speed	165 MPH
Landing Speed	65 MPH
Structural Limits	+9G -6G

STARDUSTER HISTORY
Super Acroduster One
N700XP

Again not being part of Starduster Corporation when this airplane was built puts me at a disadvantage as to its history. So most of the information is from the few magazine articles and from Bill Clouse and John Helton.

N700XP was built over a two year period during the late 1970's. It flew for the first time July 26, 1978, with Jim Osborne as the pilot.

It was the second company built Acroduster Too and incorporated some very unique features. Jim Osborne the designer and president of Starduster Corporation, has been accused of not being much of a public relations person.

But his aircraft design skills really showed during the construction of this aircraft. He did all the things that would make it a phenomenal performer.

The first thing was more horse power. So an IO-540 260 HP Lycoming was installed. The original Acroduster One had only a 200 HP Lycoming. It was also equipped with a C/S prop. Some of the other differences were not only a metal fuselage, but and all metal fabric covered wing, retaining the Starduster shape and lines, along with that it incorporated aluminum "I" struts with balanced aileron control slave struts inside them. The aircraft had a full electrical system. However no alternator was installed as the battery was kept charged by solar panels mounted on the top wing.

It also had an extra fuel tank mounted on the back of the pilots seat for ferry flights, and of course a smoke system.

It was built mostly by Bill Clouse and Norm Eaves, who were at the time Starduster forman, and mechanic respectively. The aircraft had an unusually high VNE and the cruise speed was 219 mph at 9,000. It was licensed experimental exhibition and most of the test time was flown by Eric Shilling. He also flew it to Oshkosh that year. It was quite a sensation for those who saw it, as it was only there for several days.

John and Janet Helton were also there in the two place Acroduster N750X and when Oshkosh was over they were presented with an unusual problem. They had three people, two airplanes and a rental car which had to be returned to Billy Mitchell Field in Milwaukee, WI :

The other problem was that Janet could not drive as she had no drivers license, but was signed off to solo the Acroduster Too. So John flew the Acroduster one N700XP and Janet flew the Acroduster Too and Jim Osborne drove the rental car to Milwaukee WI.

John Helton told me that you should have seen the expressions on the faces of the line personal and employees of the FBO, you have to understand that Janet was only sixteen, but looked much younger so when she taxied up and got out of N750X, they were really surprised. This was also just a few months after she had soloed it for the first time.



N700XP AT FLA*BOB AIRPORT
RIVERSIDE CA 1978



N700XP AT CSHACH WI 1978

From Milwaukee, I believe the airplane went to a small flyin at Greensboro N.C., where some aerobatic flying was done and Joe Hamilton owner of N5461, (Morgan Schrack's old Starduster Too) was the host.

The airplane then made the long trip home. Jim Osborne was the pilot during these legs. The airplane had accumulated almost 100 hours of flight time and although quite a bit of aerobatics was performed, no meaningful flight testing had been done.

So John Helton was asked to explore the envelope, and on Oct. 14, 1978, on his sixth test flight he was attempting 6 negative "G"'s. The first attempt was 190 MPH and 5 "G"'s. The second was 200 MPH and 6 "G"'s. However the new aluminum "I" struts collapsed with the upper wings bending up from the pilots view as he was upside down. John told me it sounded like a big metal door that was off in the distance being slammed shut. He shut the engine down, unhooked the belts and fell out. He thought originally his chute had caught the airplane. But later inspection proved that not to be the case. He saw the Acroduster impact, and after he landed, some farm workers took him to a phone so he could call Jim to pick him up, and come examine the aircraft. The accident was due entirely to failure of the aluminum "I" struts, as nothing else showed evidence of distress. Jim had put to much faith in engineering calculations and said he should have static load tested these aircraft components to verify these numbers. Jim was also very gracious after the accident, as he invited John to his home that evening for dinner and companionship stating that no one having been through this sort of thing should be alone, John told me that he very much appreciated the gesture.

Jim said at the time, that the airplane would be rebuilt. But with a much more extensive test program prior to flight testing. John told me that Jim really loved the airplane, and it still remains on FAA registry with Jim Osborne as the owner and builder. However N700XP was never rebuilt.

D.C.B. Editor

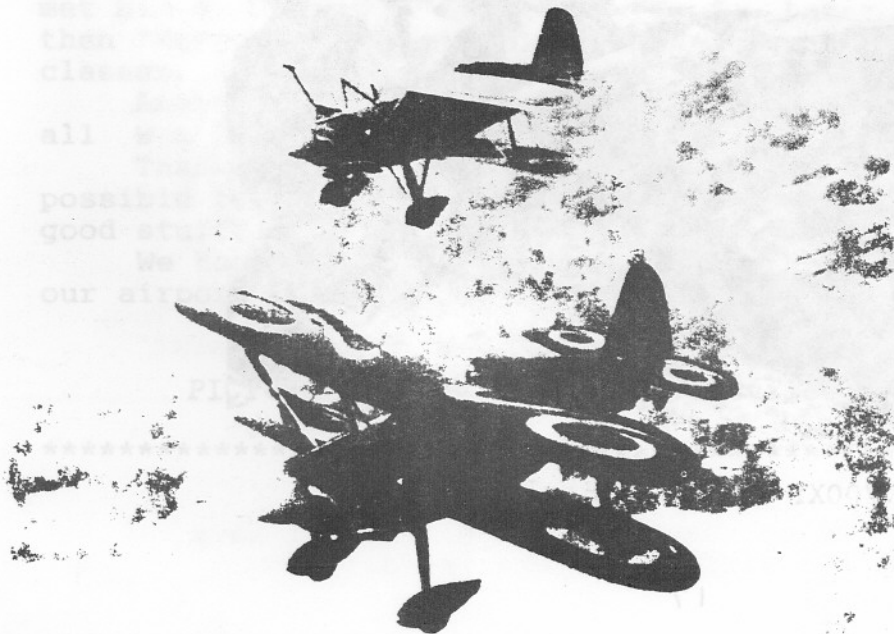

N700XP FLYING IN FOR-
MATION WITH N750X, OUR
ACRODUSTER TOO

BOTH MACHINES HAVE THE
LYCOMING IO-540 200hp
ENGINES-

HEAT FOR THE OPEN COCKPIT BIPLANE

The romance and reality of open cockpit biplane flying during cold weather can be a rude awakening, and in cold country, below 30 degrees can mean no flying at all for three to four months at a time.

Most builders do not install cockpit heat during construction if at all, besides what good would it do in an open cockpit?

Well I am here to tell you that it does make a difference in marginally cold weather, mostly between 30 and 50 degrees. Below freezing flights of more than a 1/2 hour can be uncomfortable even with heat and if dressed properly. Which brings me to the point you also must dress properly, I.E. thermal jumpsuit, scarf, leather jacket and gloves are required. But you shouldn't have so much stuff on that you can't move. The only other way around below freezing flights would be the installation of a canopy, and this we will save for another time.

The first thing you will need to decide on, is what type of heat muff you will install. I prefer the Mooney type of exhaust system, 4 pipes into one muffler, with one exhaust outlet up front. This is not a very efficient exhaust system but most of them come with a great heat muff. They are also available for the six cylinder engines as well. You can make your own heat muff or muffs if you have individual pipes or the traditional "Y" pipe exhaust system. But at any rate you must have a good heat source or it will not do much good.

NOTE: While making and installing your heat muff regardless of what type used, it is important that no exhaust (carbon monoxide) be allowed to enter the system. And although it is an open cockpit, the possibility exists for carbon monoxide poisoning to occur, depending on air flow and a leak in your system.

From Fresh air to the heat muff, black 2" mild temp scat tube can be used. But must be routed away from any hot areas, such as exhaust pipes. From the heat muff to the heat control box, 2" red hi temp scat tube must be used as the black will not work in this area due to excessive heat.

At the firewall you must have a heat control box of some sort 2" in and 2" out tubing with control arm mounting bracket and flapper shut off. There are a number of ways to make this control box and mount it on the firewall. It also must have a hot air dump, so that when the hot air is shut off to the cockpit the excess hot air dumps overboard into the engine compartment, keeping your scat tube from overheating. (See drawing of typical air box)

After the heat travels through the heat control box and firewall you will need to make a "Y" shaped tube fitting 2" in with 2 1 1/2" outlets. Where the box is mounted on the firewall will dictate the routing of the 1 1/2' tubes. See drawing for details of how to route ducting, also after the heat control box. The 1 1/2" ducting can be the black scat tubing as it is cheaper than the red and is still good for approximately 300 degrees of heat.

HEAT CONTROL BOX ITEM "A"

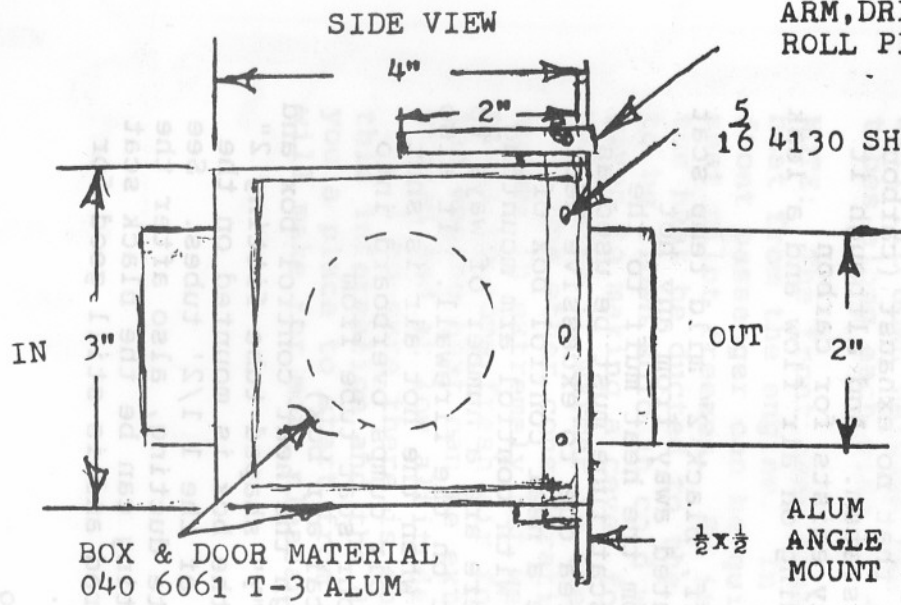

ARM, DRILL UNDERSIZE ADD
ROLL PIN AND SAFTY

ARM 3/16 ALUM

ITEM "A"
HEAT CONTROL
BOX TOP VIEW

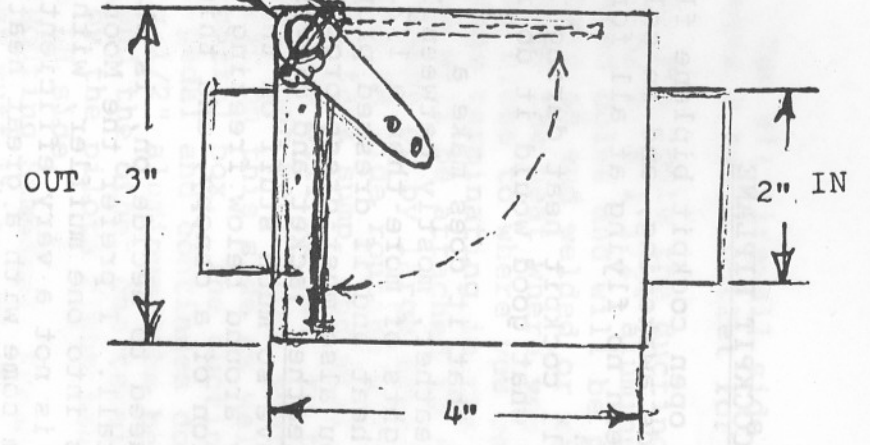

20

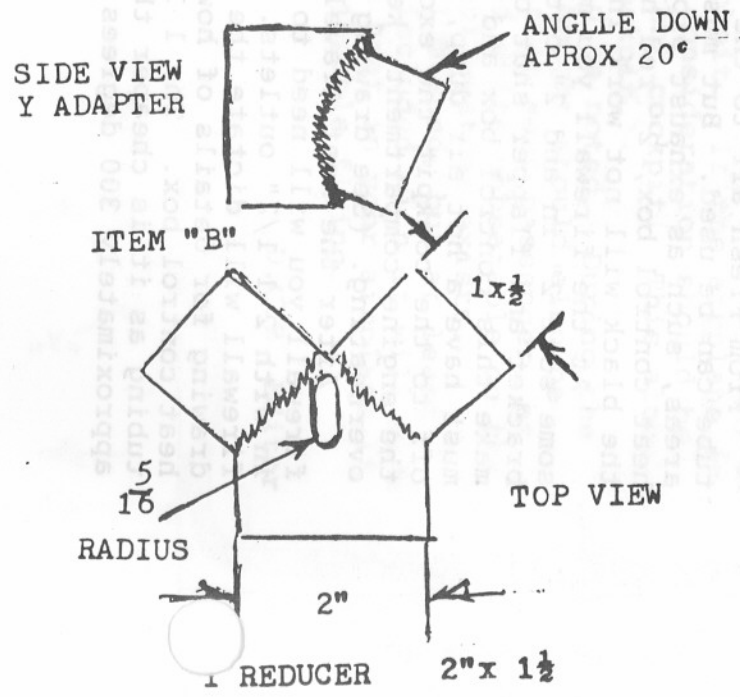

SIDE VIEW

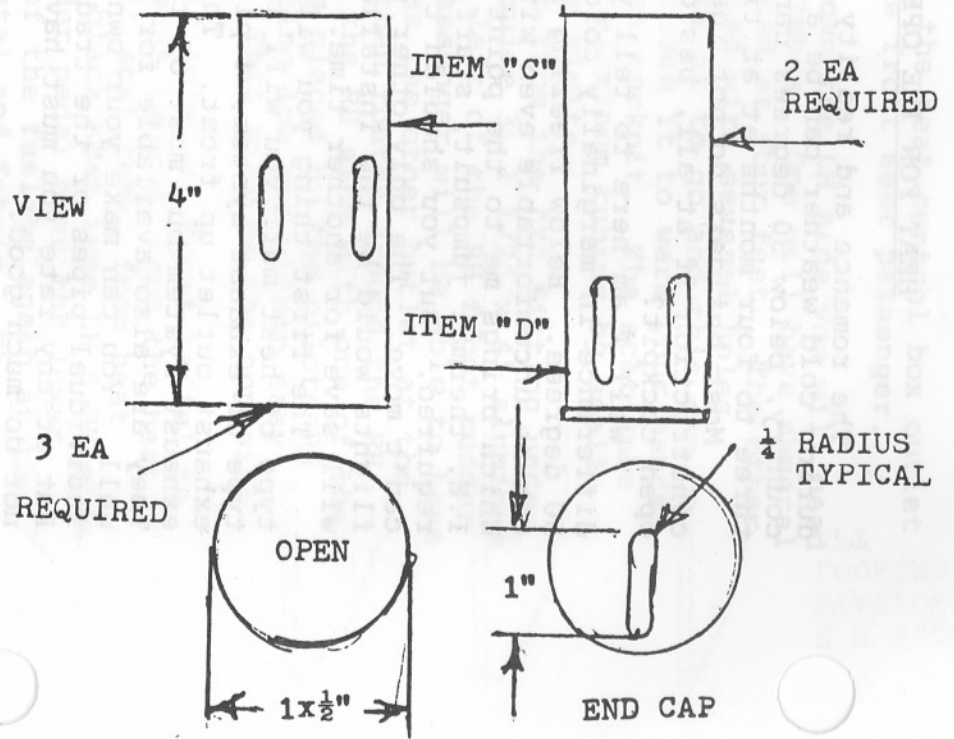

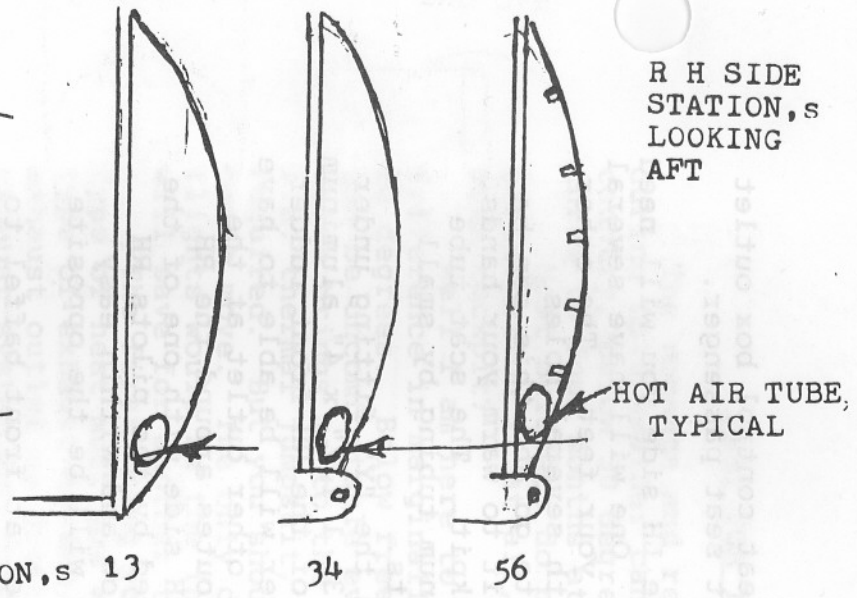
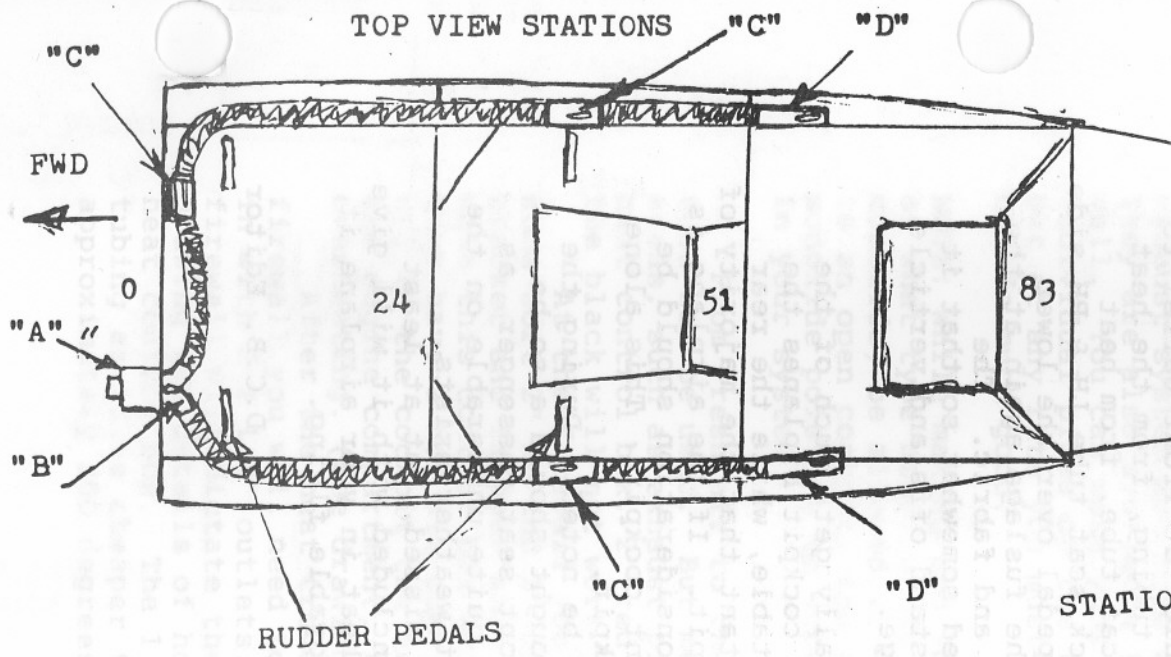

21

VIEW DUCTING LOWER L H SIDE STATIONS

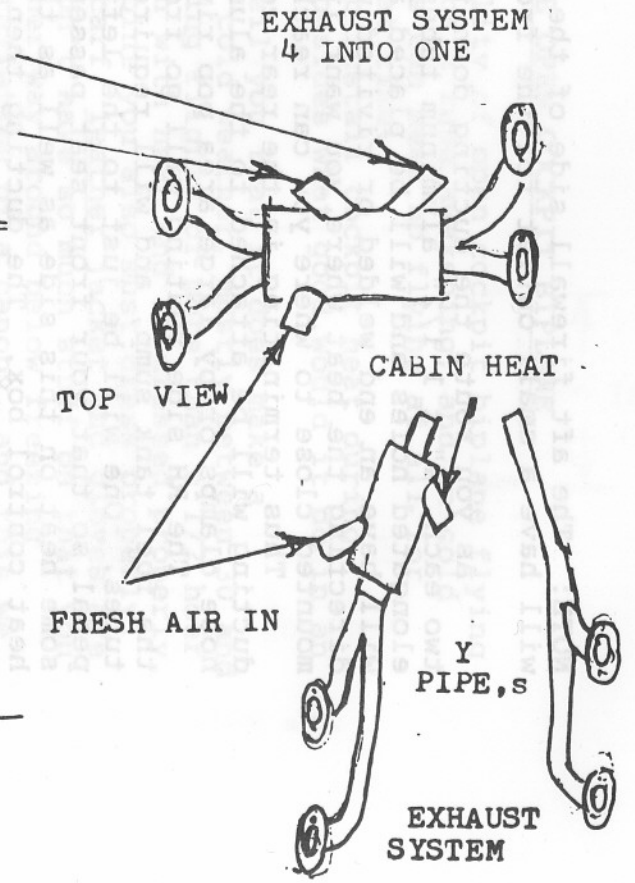
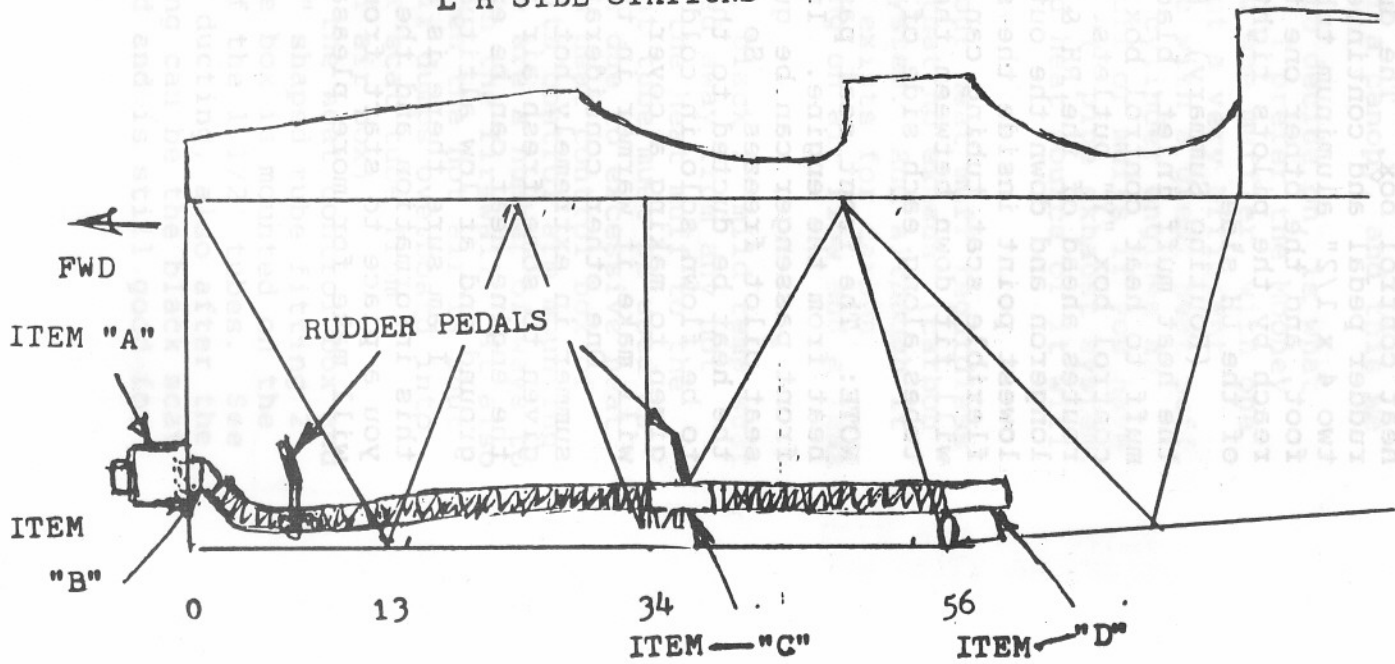

NOTE: The aft firewall side of the heat control box outlet will have a small outlet for the front seat passenger.

As you route the ducting down the LH side you will need two each, 4" x 1 1/2" aluminum tubes. One will have several elongated holes and will be placed at your feet. The other will have an end welded or riveted with several holes directing the heat where you want it to go and this can be mounted close to where you can reach it to warm your hands.

Thus terminating in the rear cockpit. The scat tube ducting will be attached to the aluminum tubing by small hose clamps or by large area pop rivits.

The RH side routing will go from the "Y" fitting under the fuel tank sump, and will require 3, 1 1/2" x 4" aluminum tubes. One will be just to the left of the RH front rudder pedal so that your front seat passenger will be able to have some heat on this side as well as the other outlet at the heat control box. The ducting then routes around the RH rudder pedal and continues down the RH side with one of the two 4 x 1/2" aluminum tube being placed by the pilots RH foot, and the other one terminating low and within easy reach by the pilots right hand. This will be the opposite of the LH side.

(Routing Summary) Fresh air inlet at front baffel to the heat muff inlet, black 2 " scat tubing, from the heat muff to heat control box. Red 2" scat tube, from heat control box "Y" outlets. 1 1/2" black scat tube LH & RH side routes ahead of the RH & LH rudder pedal over the lower longeron and down the out side of the fuslage again at the lowest point inside the sheet metal and fabric. The flexible scat tubing can be collapsed somewhat so that it will fit down between the formers, stand offs and verticle tubes along each side of the fuslage.

NOTE: The front seat passenger usually gets much of the heat from the engine. In many open cockpit biplanes the front passenger can be quite comfortable, while the rear seat pilot freezes. So it is important that the majority of the heat be ducted to the rear cockpit. If the airplane is to be flown solo in cold weather, consideration should be given to making a cover for the front cockpit. This alone will make it warmer in the rear cockpit.

One other consideration should be noted. During the summer in extremely hot weather, thought should also be given to some fresh air for your front seat passenger, as the engine heat can be extreme, and quite unbearable, on the ground and at low altitudes when hot weather exists.

I am sure there is something I missed, but at least this information and the drawings included with it will give you a place to start from and with heat in your airplane it will make for more pleasant and enjoyable flying.

D.C.B. Editor

LETTERS

David C. Baxter
5725 S.W. McEwan Rd.
Lake Oswego, Oregon 97035

January 12, 1994

Hi Dave,

Well I almost forgot my '94 dues. Not much to report about N245SD, as I do not have the wings done yet.

However my wife said I could use the back bedroom so that I could work on them. Here are a couple of pictures of what I have done.

I gave the president B.C. some drawings on my landing modification to install a radial engine. Have you seen them? What do you think about them? Well See you at Watoma '94.

John

John Clark
R2 Box 7P
Oskaloosa, KS 66066
(913)863-3117

PICTURE ON PAGE 25

P.S. You have my zip wrong.

Aero Welding
820 Brookside Blvd.
Grants Pass Airport
Grants Pass, Oregon 97256
F.A.A. Repair Station
XWDR989K

Dave Baxter
5725 S.W. McEwan Rd.
Lake Oswego, Oregon 97035

10/5/93

Dear Dave,

Sorry I missed you - I was disappointed - there were many things I wanted to discuss with you - oh well maybe down the road.

I was running thru some of my papers a few days ago - they might be of some interest for the Starduster Magazine. I have checked some of the dimensions on the Starduster Too, and look like Stolp knew what he was doing. See you next time.

Regards,

Bob Caravas

P.S. Check out the one on the tail wheels. Also I have coordinates for the M-6 airfoil if interested.

LETTERS

Dave Baxter
5725 S.W.McEwan Rd.
Lake Oswego, Oregon 97035

Dear Dave,

2-1-94

Thanks for your letter back, and also the invitation for a spin. I'll be sure to bring some gas money. It looks like I'll be down in Scapoose February 18-19-20, so I'll call you from there and see if we can meet each other.

The last Starduster Magazine again was great, as usual - no way to put it down when it comes. Thanks for doing such a fine job. There were some good ads in the back too. Do you know anything about the Starduster Too in Kona, Hawaii?

Talk to you in mid February.

Hap Schnase

P.O.Box 806 Moses Lake, Washington 98837

Bill Clouse
Stolp Starduster Corporation
4301 Twining
Riverside, California 92509

Dear B.C.

Dec.93

N76NP took us to five states "flyins" this last summer. We would park with the biplanes of course. At Salem, IND we were next to Bill Dunbar's Starduster Too N5158D, who we were happy to see win "best of show" for biplanes. We had met him at Oshkosh. Beautiful "Too". Later on to Illinois, then "Merfi" at Marion Ohio, a miniature Oshkosh with classes, aerobatics - well attended.

Another at Owgwsboro, KY. All great fun - but best of all W A T O M A !!!! WOW !!

Thanks for all your "neat" planning that made it possible for us to enjoy the comradery, and all the other good stuff at Watoma.

We hope to visit with our Starduster family anytime - our airport or yours.

Sincerely - N76NP
John & Mary Jane Reed
Evansville, IN

PICTURE ON PAGE 25



N76NP JOHN & MARY JANE REED



N445W LARRY LANGHORST

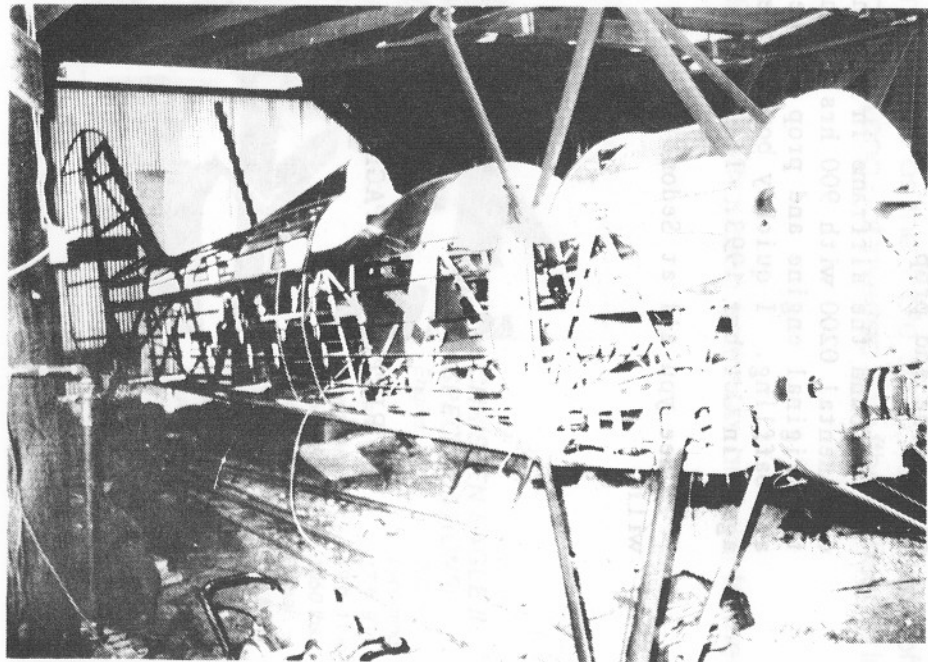

JOHN CLARKS 245 JAKE POWERED
STARDUSTER TOO UNDER CONST

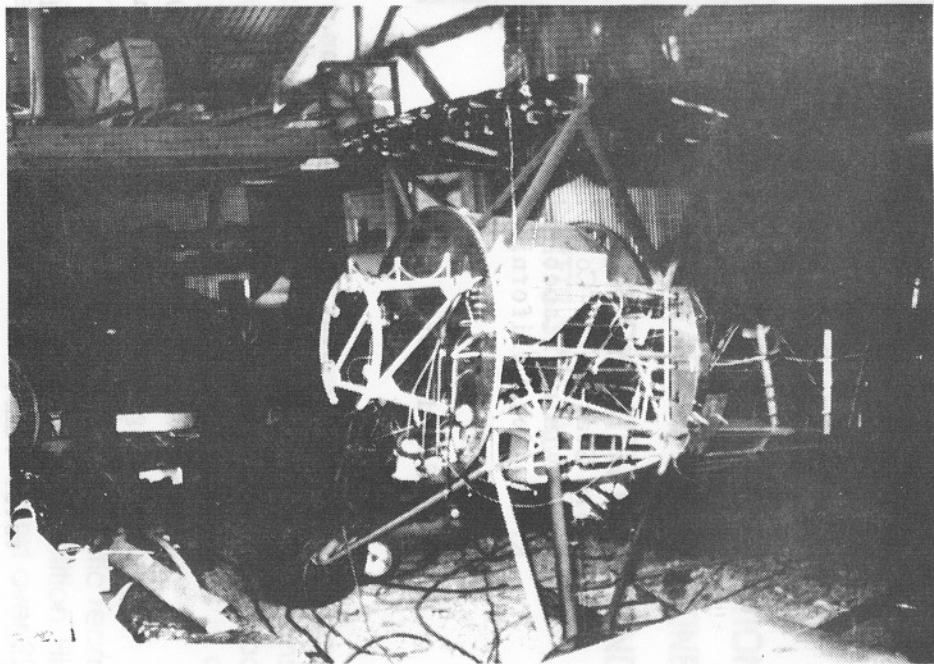

February 14, 1994

Stolp Starduster Corp.
4301 Twining Flabob Airport
Riverside, California 92509

Dear Starduster,

Please start my subscription to Starduster magazine, please find enclosed check.

I am the proud owner of a Stolp Starlet, N445W (see pictures) my Starlet was built by Dave Hiller Cincinnati, Ohio and was completed 1974. It is powered with a continental 0200A 100 H.P. engine and has a modified Cessna L19 landing gear. This airplane is mentioned in Janes All The Worlds Aircraft 1975-1976 page 468.

Mr. Hiller became ill and sold the airplane in 1985, it had 135 hrs. total time.

The new owner disassembled the airplane shortly after purchase to repaint it yellow and white, was blue and white and never completed the work. He sold the engine and prop.

I found the airframe in Dayton, Ohio in June 1993, and purchased a used continental 0200 with 900 hrs. smoh. Luckily I found the person who bought the original engine and prop and he had no need for the exhaust system, prop and baffling. I quickly bought them and reassembled the airplane and it flew again in October 1993. It now has 150 hrs. on it, what a grand machine.

See you all at Sedona in May. The Starlet won't be there, but Char and I will.

PICTURE ON PAGE 25

Thanks,

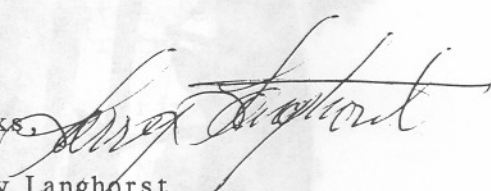
Larry Langhorst
2328 Timberman Rd.
Hamilton Ohio 45013

1-513-863-2565

LETTERS TO THE EDITOR

Bill Kolb
RD 1 Box 16
Canaan, NH 03741
603-523-7469

Dave Baxter
5725 S.W. McEwan Rd.
Lake Oswego, Oregon 97035

1/21/94

Dear Dave,

I guess it has been at least three months since you were kind enough to share with me your experience with the Starduster.

Its been running twenty to thirty below zero here for the last week or so and I've just about run out of steam. So I decided to sit by the fire today and try and catch up with long over do's.

I have been jiggging and modifying the gear to the latest mod (?) and your additional suggestions for adding some reinforcement. Just installed last week. If you recall the Maule tailwheel vertical shaft sheared and left me with the tail spring for landing. At the very last portion of the rollout (very slow) I lost directional control, ground looped and the gear tucked under and collapsed in what you refered to as "a classic".

It's going to be a month or more before I test fly because its just to damn cold. I'll try and let you know my feelings on the loc'n change.

As I told you I make my living in this crazy business and have been slowed down a bit on the gear. I'm just finishing up a Kestral Hawk which is an all metal biplane, plus the system installation phase on Q-2, and starting a complete rebuild of a Franklin powered early T-Craft.

I talked to Phil Hax and he is alive and well, he is also slowed by the weather.

You sent me a list of "stuff" you have available, but for the life of me I can't seem to find it. So if you would please send me another it would be appreciated.

The last magazine I have is the October '92, so I guess I'm missing all of '93 and January 1994. Enclosed is a check for \$30.00, which I hope will cover '93 back issues and a current subscription as well as a Starduster cutaway.

Good Flying,

Bill Kolb

January 24, 1994

David Baxter
5725 S.W. McEwan Road
Lake Oswego, OR 97035

Dear Dave,

Well, I am far enough along with my "Starduster Too" to share a few photos WITH you and everyone else. First of all, I am tired of this Michigan winter weather AND when this plane is finished, I would like to relocate to a warmer climate. Anyone out there have any good ideas? As you can see in the photo of my "Fearless Five Mallard Ducks" even the ducks came into the basement to eat on this cold winter day, but no way do I let them stay inside very long, for obvious reasons! When I built my home, the first priority was to have a walk-out basement big enough to complete my Starduster -and accommodate my "fine feathered" friends. Enough about my personal life.

The engine on my plane is a IO 360, AIA, 180 H.P. with crossover exhaust and the prop is a Hartzell, constant speed. I attached the brake cylinders directly to the rudder pedals because I was not satisfied with the travel when it was attached to the cross member of the fuselage. The brackets for the wings on the center section are extended below the center section and attached only to the cabane struts, and because of this, the cabane struts are shorter. It makes it real easy to install and remove the top wings, and I will probably make fiberglass cuffs to cover them.

The plane has a center section fuel tank, and the main tank is equipped with a flop tube. The rear instrument panel will have just about everything; horizon, directional Gyro, etc. My avionics will include a Val com equipped with their intercom module. A Flybuddy G.P.S., Transponder and encoder. I am installing a full canopy and will modify the turtle deck for the back of the canopy, but like everything else, I am really not sure until I get into it. The trim tab on the elevator is a Mac electric servo.

I had to enclose two pictures of my grandchildren giving me a helping hand and also the photo of Bill Clouse and myself. He is really saying "Now Buck, I'll tell you how its done just one more time."

Dave, nobody ever told me when you order aluminum or other materials you use the formula "need one foot, you order three feet". I feel like I am building three planes, and am amazed how improved I get after the third time. I wonder why!

Will close for now and hope to see you all at Watoma/Oshkosh 94. Say "hi" to your lovely wife.

Sincerely,



Buck Rado

Enclosure

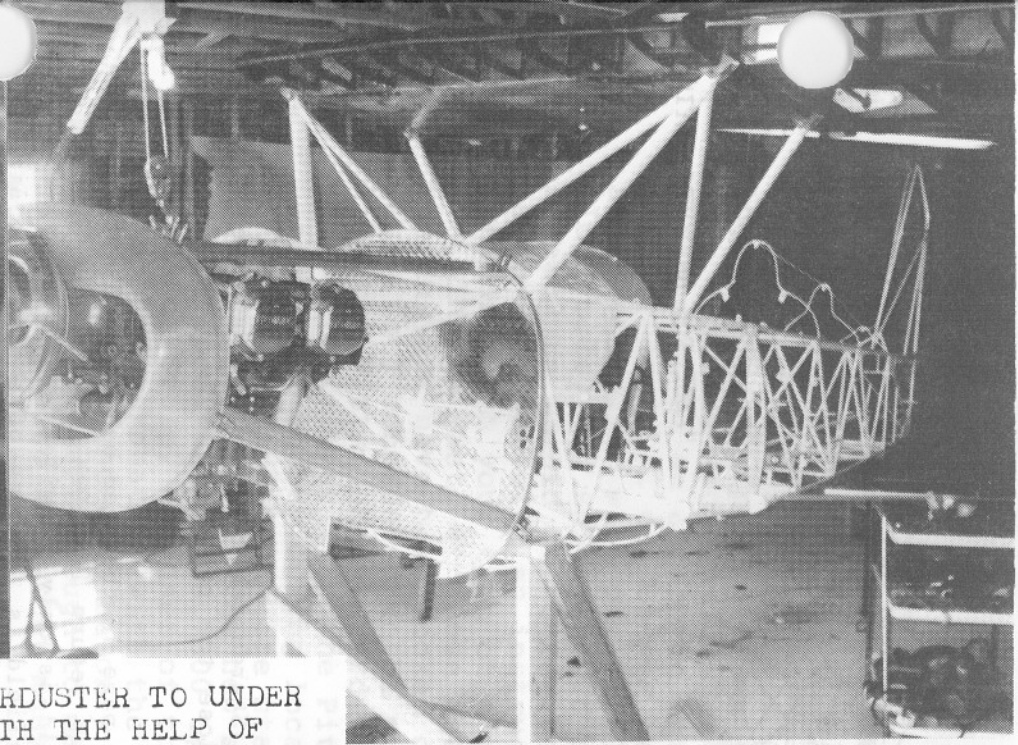
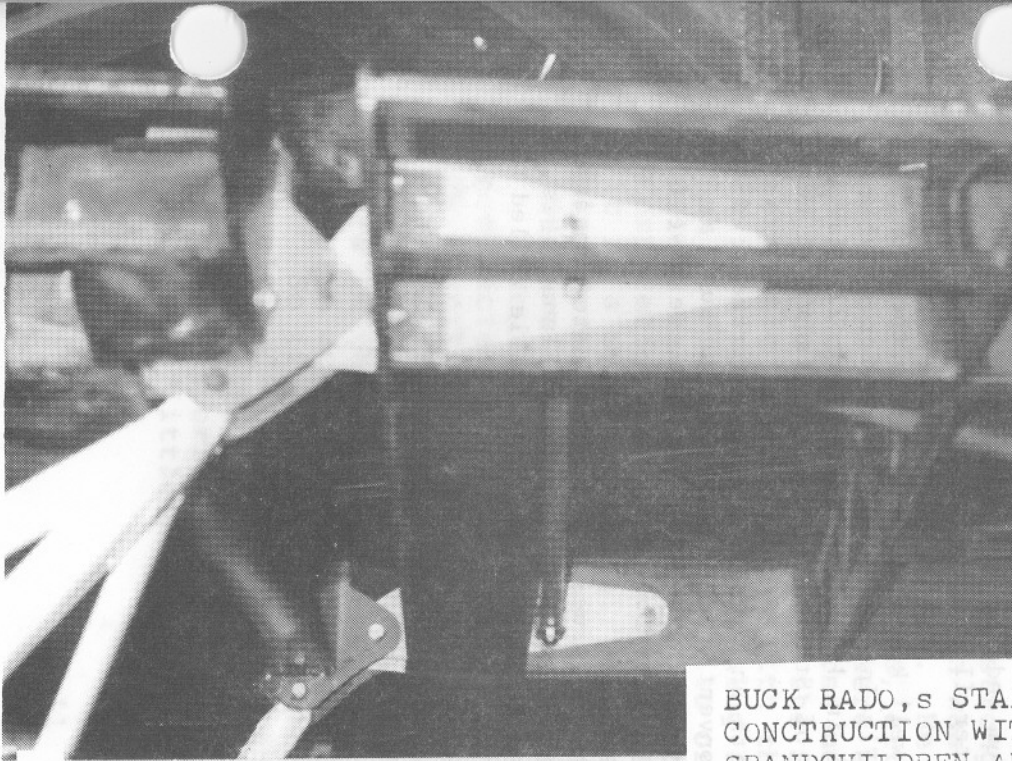

BUCK RADO, S STARDUSTER TO UNDER
CONSTRUCTION WITH THE HELP OF
GRANDCHILDREN AND BILL CLOUSE

29

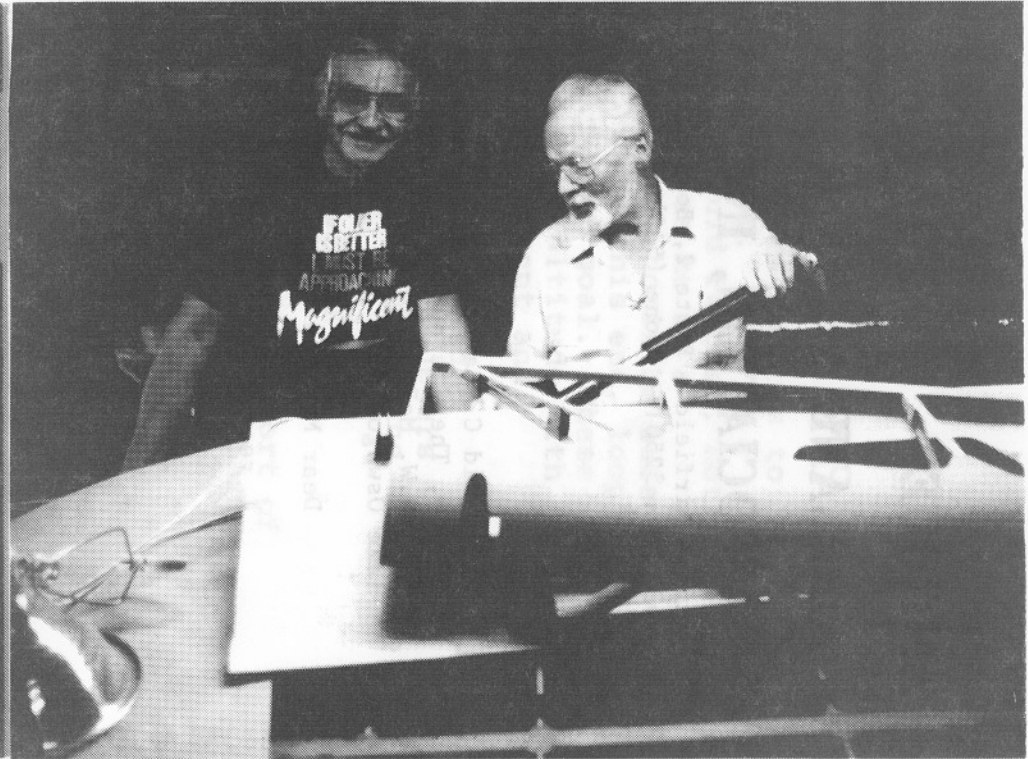
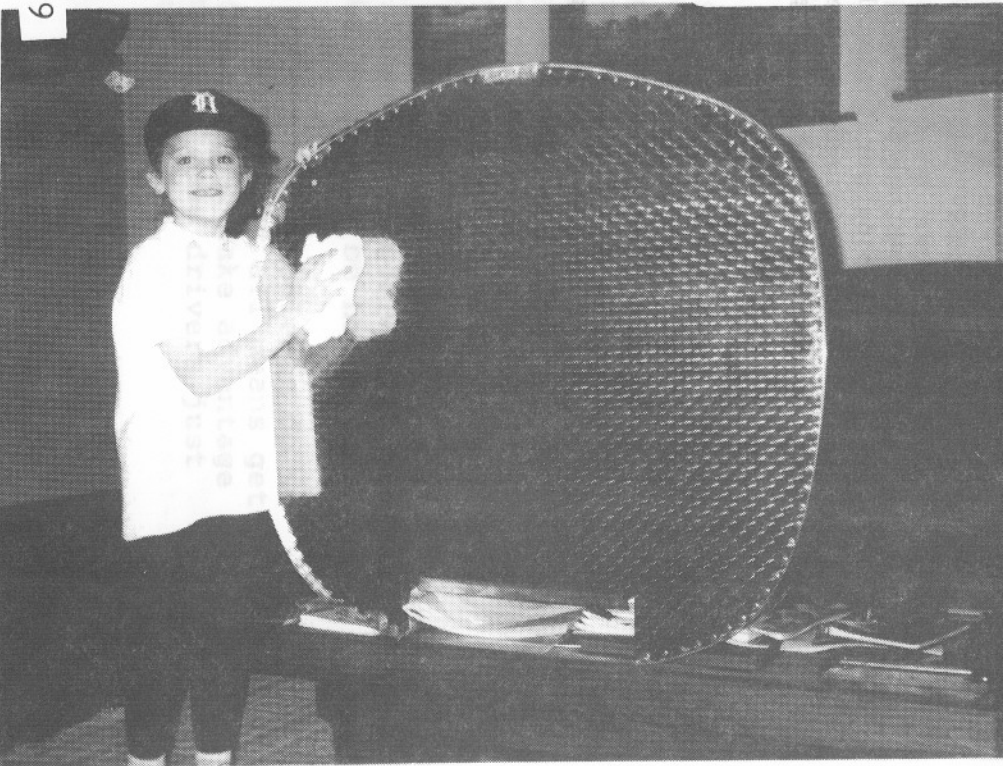

**ANTIQUÉ
AIRPLANE
ASSOCIATION, INC.**

Antique Airfield - Route 2, Box 172
Ottumwa, Iowa 52501 - Phone (515) 938-2773

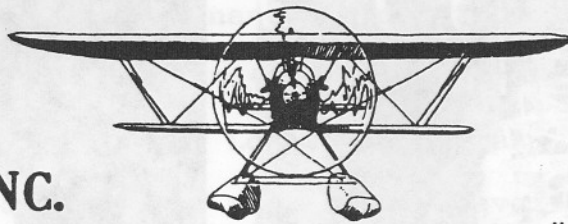

"KEEP THE ANTIQUES FLYING"

January 31, 1994

Mr. David C. Baxter
Editor, The Starduster
5725 S.W. McEwan Road
Lake Oswego, OR 97035

Dear Mr. Baxter:

I received my fourth issue of The Starduster magazine and believe I am past due with my subscription, so enclose the cover and subs form with my check.

In this your latest issue I note on page 18 that you had stopped into the Ottumwa, Iowa Industrial Airport on your return from Oshkosh. It is likely you were not aware that Antique Airfield is only 12 miles southwest of the Ottumwa Industrial Airport. Antique Airfield is the home of the Antique Airplane Association and the Airpower Museum and it would have been great to meet you and see your much travelled Starduster II.

The Ottumwa Industrial Airport is well known to us as I was the FBO there in 1953, 54 and 55 plus our National Fly-Ins were held there for many years before we established Antique Airfield in 1971. Over the past 22 years we have been fortunate to have a number of Starduster Is and IIs visit here.

Altho we are primarily involved with antique and classic aircraft we are interested in any and all types of conventional vintage design such as the Stardusters, Smith Miniplane, Steen Skybolt, et cetera. In fact, we have five homebuilts in the APM in addition to 41 factory built aircraft.

So we look forward to receiving more issues of The Starduster magazine and found your last issue the best yet. Incidentally, Molly Flanagan is an AAA member and we have a very active AAA Chapter at Schellville called The Schellville Antique Escadrille.

If your travels bring you back to the Midwest we hope you will stop by and hopefully I will be here to show you around.

Yours truly,

A handwritten signature in dark ink, appearing to read "RLT" or "Bob Taylor". The signature is written in a cursive, somewhat stylized font.

Robert L. Taylor
President

RLT/cmr
enc.

HORROR STORY

I have spent the last 46 years in aviation, both in the military and as a civilian. As both pilot and mechanic/flight engineer, fixed and rotary.

Flying/fixing for a living developed over the last ten to fifteen years a desire for a personal fun airplane. In that time I have owned and flown extensively a Piper, Clipper an Aeronca Champ. I have also flown many homebuilts and pre and post war (WW2) "Fun Airplanes". I guess in a desire to relive or recapture lost youth, I developed a yen for a biplane. Waco's, Stearmans, Great Lakes, and Fleets were just out of my financial ball park. Even accepted home built designs were more costly than acceptable. I would not consider a project.

I came across a good homebuilt design airplane that had approximately 100 hours of flight time and a newly overhauled engine (O-360), both of which had been in storage for ten or more years, and the airframe had been disassembled. I flew a considerable distance to perform a prepurchase inspection that was probably more detailed than I would have done for a paying customer.

I performed an extensive visual of the airframe and engine, as well as an engine compression check and visual inside the cylinders with no critical discrepancies observed. (Although there were numerous noted assembly and repair/modification work required).

One item noted was that two cylinders were color coded chrome and two were not. The same serial number as had been in the aircraft for the recorded flight time, and that the engine had been majored by a reputable shop some 400 hours ago, but it had virtually no enteries since. Questioning revealed that that the engine had been "swapped" by the owner/builder and "overhauled" by him after a sudden stop.

The following is what somebody that is suppose to know what he is doing and does for a living can fall into.

The builder had relocated some 2000 miles away and was only accessible by phone. A number of calls revealed that the builder was an ex major airline captain, and that he and an "experienced friend" had rebuilt the engine that had been salvaged from an aerobatic aircraft that had augered in. He could not explain why two cylinders were coded chrome and two were not. Although he did recall that all new rings had been purchased and they were all the same part number.

The aircraft had been delivered over the road (thank God) to my shop. Due to questions about ring material and a now developed skepticism as to the most recent "overhaulers" credentials I looked at the engine with a doubting Thomas mind set.

I pulled all four jugs, not only to check ring material, but to get a good look inside. All jugs had been chromed with steel rings and new valves. The camshaft was new or reconditioned as was the crank. The crankcase had been repaired by a reputable shop and the crank runout was well within tolerance.

I did at this point find that the two forward crank case (cc) oil plugs were not installed. I also noted that all engine controls were solid i.e. rods thru bellcrank back to quadrants. The cyl pushrod seals had been heavily siliconed. I also noted the cc parting surfaces were also heavily siliconed. I lapped some valves, rebuilt both mag's, replaced the hard controls with push pull, replaced push rod seals and cylinder O rings, installed oil channel plugs, replaced all fuel and oil lines, bench checked starter and generator.

I turned over the engine with starter and found fresh oil at cc pressure gage connection and at oil cooler. Started engine, no oil pressure, installed test gage at cc, started and ran engine 15-50 lbs oil pressure, checked relief valve, reseated ball and added three washers. I then primed the oil pump thru thermal valve cavity. Ran engine, 15-20 psi,. Completely removed inverted oil system and returned to standard configuration. Primed oil pump, ran engine, 15-20 psi, Complete Frustration !!!!! Started to suspect wrong main bearings, bad oil pump etc. .

In conversation with my friend the Grand Guru, I mentioned that I had found the front channel plugs missing. In his infinite wisdom he suggested the wild possibility that the internal ones also might not have been installed. (These are in the accessory case and can not be seen from the outside).

He happened to have a disassembled engine in his shop and from observation, suggested I might be able to confirm installation by inserting a long thin rod with a small hook on it thru the front channel hole. Using this method, it appeared to indicate that the rear plugs were not installed, as the rod went into the accessory case and grabbed thru 360 degrees of flange.

With the engine still installed we pulled the accessory case. After setting aside the case, the first look was for the plugs, which were both missing (result: oil circulation thru channels and could not build up pressure). The two of us standing there looking at these missing plugs from a supposedly overhauled engine, then commenced to indulge in considerable four letter epithets for the "Rocket Scientists" that had done this overhaul. As we were standing looking forward at the accessory section the anger and adrenalin subsided and I looked down. (Note: With the accessory case off, approximately 6" of open oil sunp is visible). I said to my partner, "Did you drop a rag while we were removing the case". He said no I didn't have one. I said then, "What the hell is that". Wherein we both took particular note of a large "glob" of oil soaked material in the sump almost completely covering the oil pump suction channels. Upon removal it turned out to be a rag which measured 20" wide x 30" long (approximately the size of a bath hand towel). The rag was not torn or shredded in any way, but was configured as a large "glob". The initial thought was that the rag had plugged a mag hole and fallen down into the sump. Observation indicated it could not have migrated without being torn by gears.

Further, had it plugged a cylinder hole it could not have migrated without being torn by crank or rods. (We had not removed the rods at cylinder removal). Nor was the rag visible with careful inspection of the crank case at cylinder removal. Hence the rag had to have been there when the accessory case (or sump) was installed.

It was further observed that the cc gasket had been installed with large quantities of silicon and that one of the cs idler gear shafts had the two hole locking tab installed, but not bent to lock the heads.

At this point I decided to remove the entire engine and completely disassemble and overhaul from scratch. (It should again be noted that I had intended to fly this airplane, and I had more than one nightmare as to the results of what might have been).

The engine was disassembled in accordance with the Lycoming overhaul manual. It was found that the original oil pump was suspect from the condition of the shaft and gears. The cs gear was original (no scallops), there were globs of silicon thru out the engine. The exhaust valves had been updated to 1/2" but the old rocker arms were installed.

Scrupulous inspection of parts revealed all or most new parts, cam shaft, crank, rods bearings, etc. The part numbers did match the current or two previous editions of the part manual. (although parts did check to new limits). Checking with Lycoming Tech reps was fruitless (if it wasn't in the parts manual, "replace it". I did eventually contact a long time employee (Ron) in the parts room who was absolutely indispensable in sorting out this fiasco. Ron researched forging numbers, part numbers, and descriptions and we were able to determine that the installed parts were approved for this engine. I can not give enough credit to Ron, whose long experience and memory of Lycoming engines ancestry and part changes/updating resulted in not junking this engine in its entirety. My long confidence in Lycoming was restored. So much for replacing years of experience with computer data bases. (Which the tech reps can't seem to go beyond)

Additionally a installed rocker arm was found to have a severely chipped bushing. At this point all steel parts were magnafluxed, new oil pump gears, housing and shaft were ordered. The cs gear was sent out for scalloping, new exhaust rockers, a major overhaul gasket kit was ordered and the rocker arm was rebushed.

After removing literally masses of silicone from everywhere, reassembly was started in strict accordance with the Lycoming overhaul manual. It became immediately obvious that while the crank case had been repaired/reworked professionally, that numerous parting surfaces had been damaged subsequently by hammers, screwdrivers, prying and whatever. It also became obvious that all ten O rings stud seals had been left out, one of the front locator dowels had been damaged, and that short bolts had been used to attach the generator mounting bracket resulting in stripped cc threads. In addition, the generator to bracket hardware was non AN Taiwanese and with incorrect sizing. There had been no silk thread used at cc parting surface during assembly per Lycoming.

SUMMARY

MISSING PARTS

Stud O rings - 10
Oil Channel Plugs - 4
Silk Thread - 2

WRONG PARTS

Generator Braket Attach Bolts - 2
Generator Mounting Bolt - 1
Rocker Arms - 4
Cam Shaft Gear Locking Tabs - 2

IMPROPER INSTALLATION

Stripped threads - 2
Idler Shaft Locking Tab - 1
Oil Pump Gears and Shaft - 3
Intake Rocker arm - 1
Crank Shaft Gear

EXTRA PARTS

20" Wide x 30" Long Rag - 1
Silicon - 2 tubes (estimated)

TOTALS

Missing - 16
Wrong - 9
Improper - 8
Extra - 3

36

The lesson from the for going should be obvious. Unless you have "REAL" experience or minute to minute access to it, the appropriate tools, manuals, materials and resources, DON'T attempt to do any major work on a aircraft or engine meant for flight, regardless of whether a homebuilt or not and regardless of wether the FAA permits you to or not.

Regarding the retired airline captain and his friend "with lots of experience with auto engines".

I vow I'll never fly his airline if he'll promise to never ever touch another engine meant for flight. Further I won't tinker with my auto or truck engine if his friend will stay away from airplanes.

*** Editors Note ***

This story you've just read is true, and the author has requested that his name be withheld. - D.C.B. Editor

Oscar Bayer



Starduster Too
N490B

Dave Baxter
5725 S.W. McEwan Rd.
Lake Oswego, Oregon 97035

7 March '94

Dear Dave:

Just about a month ago, I received a call in the early a.m. - fellow asked me if I was Oscar Bayer? I said yes (not bad for early in the a.m.) Next he asked me if I owned an aircraft "N" number 490B and if it was a Pitts? I told him I did indeed own N490B but that it wasn't a Pitts - it was a Starduster. Next he asked if I was left handed? No.

Now he tells me his tale - He bought a project 4 July 1993 for \$5,000 from a friend? He received a FAA form 8050-2 "Aircraft Bill Of Sale" with my "N" number and the aircraft manufacturer and model, a Pitts "Little" signed by (name of Seller) Oscar Bayer! A left handed type did it.

After some discussion with this gentleman, I asked if he would send me a copy of said "Bill of Sale". He said he would and eventually did. Meantime I called the AOPA for advice - they recommended the following:

- 1.) Don't call FAA aircraft in OK City - They would only confuse the issue.
- 2.) Do call my local FSDO and tell my story.
- 3.) Notify my local airport administration that the aircraft is not sold, and to stop anyone trying to take possession of it.

Anyhow I talked to the FSDO folks and sent them a copy of the bogus bill of sale. No reply from them as yet.

I told as many people at my airport what was going on and wrote a similar letter to my local EAA chapter detailing this story - hoping they will publish it in the newsletter - Finally, I have been a lot more careful when I have the aircraft outside the locked hangar!!

Imagine this - you fly into Sedona, tie your machine down and go to town for dinner and dancing - Joe Schmuck II shows up at the airport, unties you aircraft and starts to take it away. When questioned by the local fuzz, he presents a "Bill of Sale" signed by you! Hot wires the machine and flies off with it.

Even if you eventually find the aircraft, imagine the hassle in trying to prove that you didn't sell it and trying to get it back!

Hope you will pass on the word Dave.

Regards,

(not Left handed)

P.S. See you in Sedona!

35

14th ANNUAL STARDUSTER OPEN HOUSE

WHEN: MAY 13, 14, 15, 1994

WHERE: SEDONA AIRPORT (SEZ)

In Sedona, Arizona - Approximately 100 mile north of Phoenix

We would like to fill Sedona with biplanes. Come help us celebrate our 14th annual Open House.

The tentative schedule of events are as follows:

Friday, May 13th : day - Arrival and parking south ramp, adjacent to airport terminal. Registration in terminal lobby. Dick & Donna Lucas will be on hand to greet early arrivals.

Friday, May 13th : evening - At 5:00 p.m., 1700 hrs early bird arrival "Wing Ding" in Dick's hangar. Snacks & Drinks.

Saturday, May 14th : morning - Dawn patrol from Sedona to Prescotts Love field for special Starduster Breakfast. Briefing at 0545. Takeoffs at 0600. Breakfast at 0630.

Saturday, May 14th : day - More arrivals, local flying to enjoy the world reknown scenery that only Sedona can provide. Use of terminal conference room for hangar flying. War stories, totally hands off first flights and how to make your Starduster go faster. (Lie about it that's how!)

Saturday, May 14th: evening - At 5:00 p.m., 1700 hrs caterer sets up for a "Cowboy Cookout" of barbeque brisket or chicken breast, served with beans, potatoe salad, garlic toast and apple cobbler. Approximate cost for complete dinners will be \$16.00 per person. Dick Lucas must have dinner reservations no later than the **May 11th** please call him if you haven't made reservations. After dinner there will be awards and entertainment. Our guest speaker will be Jack May. Jack is a former WWII Royal Airforce fighter pilot trained in Arizona and then going back home to fly Spitfires and Mustangs in combat with the German Luftwaffe. This will be a very enjoyable experience.

Sunday, May 15th : day - Say your goodbyes and launch for home. Perhaps some organized departures with flights departing to the west, to the north and to the east.

Also there is a great restaurant that serves breakfast and lunch on the airport.

For additional information please call: Bill Clouse 1-800-833-9102
Dave Baxter 1-503-639-8792
Dick Lucas 1-602-282-3030

If you plan on staying at the Sky Ranch Lodge, reservations should have been made by now. But if you haven't make sure you tell them that you are with the Starduster group and that you know Dick Lucas as they might still have a few rooms left.

STARDUSTER TOO. KITS. PARTS. AND COMPONENTS ----- \$ PLANS \$150.00
 (INCLUDES. FAA MANUAL & BUILDERS MANUAL)

WING KIT - INCLUDES EVERYTHING NEEDED TO BUILD THE WINGS, EXCEPT SHEET 15 SPARS ARE FINISHED. RIBS FINISHED. TRAILING EDGES FINISHED & ALL FITTINGS SHEARED TO SIZE -----	\$2992.00
SPAR KIT - ALL SPAR FINISHED -----	857.00
RIB KIT - ALL RIBS FINISHED -----	886.00
SPAR PLATE KIT - FINISHED -----	88.00
WING FITTING, SHEARED TO SIZE -----	133.00
TRAILING EDGES - FORMED ALUMINUM -----	127.00
FLYING WIRE SET, COMPLETE -----	1857.00
FUSELAGE KIT - SHEET 11 -----	866.00
CABANE STRUT KIT - SHEET 12 -----	386.00
I STRUT KIT - SHEET 12 -----	348.00
LANDING GEAR KIT. NEW SHEET 14 -----	465.00
CONTROLS KIT. KIT - SHEET 13 -----	424.00
FUSELAGE FAIRING KIT - SHEET 9 -----	264.00
BRAKES. TAIL WHEEL & FUEL SYSTEM. - SHEET 16 -----	629.00
ELEVATOR. STABILIZER. RUDDER. FORMED RIB. - SHEET 10 -----	459.00
COVERING KIT -----	926.00
FIBERGLASS KIT (COCKPIT. TURTLEBACK. NOSE COWLING. WHEEL PANTS)- PICKED UP-----	537.00
PACKED -----	622.00
GAS TANK. MAIN INVERTED. WITH SENDER & FLOP TUBE -----	445.00
GAS TANK. CENTER SECTION -----	260.00
ENGINE MOUNT. LYCOMING ENGINES -----	465.00
EXHAUST SYSTEM. CERTIFIED STAINLESS STEEL 4 CYL. 150 TO 180HP -- ----- 200HP --	365.00
6 CYL. -----	474.00
	525.00
TWO SWIVEL JOINTS.ADD -----	110.00
CARB HEAT BOX.ADD -----	90.00
<u>PREFABRICATED COMPONENTS</u> ALUMINUM LANDING GEAR -----	1100.00
WING READY FOR COVER -----	9790.00
BASIC FUSELAGE ASSY -----	2087.00
HORIZONTAL TAIL. COMPLETE -----	1089.00
LANDING GEAR. COMPLETE -----	929.00
CABANE STRUTS. BOLT ON TYPE -----	703.00
CONTROLS ASSY. INCLUDING TWO STICKS -----	439.00
I STRUTS FOR WINGS -----	863.00
BELL CRANK ASSYS. TWO -----	242.00
COMPRESSION STRUTS. TWO. CENTER SECTION -----	90.00
COMPLETE WELDED ASSY. -----	9900.00
CONSISTS OF FUSELAGE. LANDING GEAR. TAIL ASSEMBLIES. CABANE STRUTS. CONTROLS. ALL STANDOFFS. FORMERS. BRACKETS. ASSEMBLED. INSPECTED. TESTED.	

***** PRICE SUBJECT TO CHANGE WITHOUT NOTICE *****
 ABOVE PRICE DO NOT INCLUDE PACKING & FREIGHT CHARGE

ACRODUSTER TOO KITS. PARTS. AND COMPONENTS ----- PLANS \$150.00
 (INCLUDES. FAA MANUAL & BUILDERS MANUAL)

WING KIT - INCLUDES EVERYTHING NEEDED TO BUILD WINGS. EXCEPT COVERING. SPARS ARE FINISHED. RIBS ROUTED. TRAILING EDGES FINISHED. AND ALL FITTINGS SHEARED TO SIZE -----	\$2956.00
SPAR KIT - ALL SPARS FINISHED FOUR SIDES -----	851.00
RIB KIT - ALL RIBS ROUTED. AND CAP STRIPS GROOVED -----	580.00
SPAR PLATE KIT - FINISHED -----	88.00
WING FITTINGS SHEARED TO SIZE -----	219.00
TRAILING EDGES. FORMED ALUMINUM -----	127.00
FLYING WIRE SET. COMPLETE -----	1800.00
FUSELAGE KIT. SHEET 2 (WITH 3 CURVED TUBING - \$15.00 EXTRA) --	633.00
CONTROLS KIT. SHEET 35 -----	120.00
CONTROLS INSTL. KIT. SHEET 36 -----	200.00
AILERON CONTROLS INSTL. SHEET 38 -----	272.00
CABANE STRUT KIT. SHEET 5 -----	361.00
LANDING GEAR KIT. SHEET 3 -----	425.00
HORIZONTAL TAIL KIT. FORMED RIBS -----	383.00
RUDDER KIT WITH FORMED RIBS -----	82.00
I STRUT INST. SHEET 37 -----	380.00
COVERING KIT -----	814.00
SEAT. BRAKES. AND TANK INST. SHEET 39 INCLUDES TANK. FLOP TUBE AND GAS GAGE -----	644.00
FUSELAGE FAIRINGS. SHEET 40 (EXCLUDES TURTLEBACK) -----	626.00
COMPLETE FIBERGLASS KIT ----- PICKED UP -----	351.00
----- PACKED -----	375.00
GAS TANK. MAIN. INVERTED. WITH FLOP TUBE & GAS GAGE -----	490.00
GAS TANK. CENTERSECTION -----	260.00
ENGINE MOUNT. LYCOMING ENGINES -----	465.00
EXHAUST SYSTEM. CERTIFIED STAINLESS STEEL 4 CYL. 150 TO 180HP-----	365.00
----- 200HP-----	474.00
6 CYL. -----	525.00
TWO SWIVEL JOINTS ADD. -----	110.00
CARB HEAT BOX. ADD -----	90.00
PREFABRICATED COMPONENTS ALUMINUM LANDING GEAR -----	1100.00
WINGS. READY FOR COVER -----	9790.00
BASIC FUSELAGE ASSY. SHEET 2 -----	2170.00
HORIZONTAL TAIL. COMPLETE -----	1089.00
I STRUTS. FOR WINGS -----	762.00
LANDING GEAR. COMPLETE -----	929.00
CABANE STRUTS -----	703.00
CONTROL ASSY. INCLUDING TWO STICKS -----	450.00
BELL CRANK ASSYS. TWO -----	170.00
COMPRESSION STRUTS. TWO SECTION -----	90.00
COMPLETE WELDE ASSY. -----	9900.00

CLASSIFIEDS

ADVERTISING CLOSING DATES : DECEMBER 1, MARCH 1, JUNE 1, & SEPTEMBER 1.
CLASSIFIED ADVERTISING RATES : \$3.00 PER COLUMN INCH, MINIMUM CHARGE \$3.00.
MAKE CHECKS PAYABLE TO STOLP STARDUSTER CORPORATION. THANK YOU.

SUPER STARDUSTER ONE: 307 TT 216
SMOH on AIO360A1E, 200HP, C.S. prop,
wings covered '90, fuse. and tail covered '92.
Good entry level aerobatic airplane. (408)
385-5083.

STARDUSTER ONE, 234TT, Lyc. 0-290, 99
SMOH, Nav Com, txp., encoder, strobe, ele.
pitch trim, Cleveland, Very nice. Ready to fly.
\$15,000. Salt Lake City, Utah based. (404)
907-0637.

STARDUSTER ONE SA-100, 930 TT, SMOH
355 Lyc. 0-320, inverted fuel & oil, PS-5 carb.,
removable plexiglas canopy, hand-held radio
w/internal mount and ext. ant., always hangered,
\$13,500. (919) 965-8490.

STOLP ACRODUSTER TOO, always
hangered, 165TT since new IO360A1B 200HP,
chutes, intercom, 100 Genave, David Clarks,
\$33,000 OBO. (916) 333-1148.

STARDUSTER TOO, IO540, 98% complete,
finish canopy, less paint and battery, full
inverted. Best offer over \$16,500.
(512) 859-2510.

STARDUSTER TOO, 168 TT, 230 HP Cont.,
450 SMOH, 100 SPOH, Stits 4 yrs., NavCom,
landing light, \$28,900. (216) 499-7046

'93 STARDUSTER TOO, 260HP, 60-TT,
550-SMOH, full bubble canopy, Mode-C,
MK-11, exquisite throughout, \$32,000 firm.
(801) 825-8347.

V-STAR WING KIT For Sale.(704) 252-3249.

STARDUSTER TOO. NEW FABRIC and
paint. Full Christen inverted. O-360 and
aerobatic Hartzell. No damage history. 2
place canopy, heater, Nav lights. (402)
392-0257.

STARDUSTER STARLET with 1835cc
engine. Low time. Flyable. Need annual.
Asking \$9500 or trade for flyable or classic
project. Call Richard at (904) 994-4802

ACRODUSTER TOO, Fuselage &
tailfeathers welded, throttle & control sticks
installed, 0540 motor mount, gear complete
w/wheels brakes and tires, two seat packs,
V6 engine and literature for conversion,
misc. materials and plans. \$5600
Harry (209) 683-0365.

1991 RANGE DUSTER, 200HP Ranger.
This is a low time beautiful red with black
trim well built airplane with avionics, it is
currently based at Chino, CA. Price is
\$20,000 contact Al Hooper (714) 587-0256.

WANTED: 3 PIECE STEARMAN TYPE
ANTIQUÉ WINDSHIELD AND FRAMES.
Call Bob Pasani, San Mateo, CA. (415)
347-2559.

MACWHYTE FLYING WIRES, Wire sets
for the Starduster and Acroduster Too have
increased substantially. Now almost \$1850.
CECONITE COVERING PROCESS, most
items supplied by Ceconite have increase by
20%. Please call for current price an
availability. B.C.

AS ALWAYS YOUR ORDERS WILL RECEIVE OUR PROMPT ATTENTION, QUALITY
PRODUCTS AND WORKMANSHIP AT A COMPETITIVE PRICE.

