

The *Starduster* Magazine

January 2000



In This issue –

- How it's done in South Africa -6
- Look out when you land! -11
- Survival Kit Container -28
- Breathing Easy -29, -35

The *Starduster* Magazine

Vol. 30, No. 1, January 2000

Stolp Starduster Corp.

129 Chuck Yeager Way
Oroville, CA 95965-9200

530.534-7434

530.534-7451 (FAX)

takeoff@starduster.com

For technical help

tech@starduster.com

President

Les Homan

Secretary

Mary Homan

Office Manager,

Sales Manager

Ken Nowell

Consultant

Bill Clouse

BCPREZ1@AOL.COM

The Starduster Magazine

Editors

Clay Gorton

801.292-0127

cgorton@burgoyne.com

Glen Olsen

801.292-2708

801.943-2931 (Home)

Regional Editors

Oscar Bayer

Arroyo Grande CA
805-489-0915

Dan Benkert

Rapid City, SD
605.393-2270

Max Bennett

Buffalo NY
716-634-2107

Bob Dwyer

Tucson AZ
520.722-3117

Charles Glackman

Evansville IN
812-867-3103

Chuck Krabbenhoft

Sabin MN
218-789-7250

Fred R. Myers, III

Conyers GA
678-422-6806

Harry Mackintosh

Wimbledon England
181-94-62571

Table of contents

Front Cover

Chuck Krabbenhoft, Sabin, MN, smoking again in his 'Duster N249AK

3 President's Message— Les Homan

Correspondence

4 Letters from—

■ Bob Griffin, Warren, OH ■ Craig Phillips, Rancho Mirage, CA

■ John Majure, Biloxi, MS ■ Chris DeBaun, Lakeville, MN

■ Randy Cordray, Naperville, IL ■ Wayne Bundy, Footner Close,

Romsey, Hampshire, England ■ Jeff Hardy ■ C5Babe, Lakeville,

MN ■ Dan Benkert, Rapid City, SD ■ Gene Glackman, Evansville, IN

6 Paul Roberts tells how it's done in South Africa

8 Dave Millikan tells how it's done in New York

9 Persistence pays off

10 The Saga of 4226Y, Part three

11 Where do you put your eyes when you land a Starduster?

17 Oroville Starduster Open House

18 The common bond between a pediatrician and a commercial artist

19 Photos of outstanding Stardusters

23 Common bond, cont'.

24 Stardusters in the news

A pilotless plane in 1923??

Tech Tips

25 On the level

26 Slave Struts Q&A

28 Sit on your survival kit

29 How to breath easy while painting your Starduster

Safety

31 How to enter the traffic pattern

33 The ten biggest lies, cont'.

35 How to breath easy when your com system goes out

37 Classifieds

Inside Back Cover

This beautiful Starduster One was photographed by Carolina Labby at the Oroville Open House in May, 1999.

This magazine uses material submitted by its readers. The articles printed do not necessarily represent the views or opinions of *The Stolp Starduster Corp.* or *The Starduster Magazine*. The Corporation and the Magazine assume no responsibility nor liability for the accuracy of the printed material.

President's Message

Les Homan

Hope this finds all doing well. It is time to reflect on the accomplishments of this year and set new goals for next year.

Getting product out the door was one of our largest problems this past year. We have set high expectations for 2000. Starting the last week in December, we finally have the ingredients to move forward at a faster pace. Steps are being taken to move away from where we have been and into a better place. We may have to get more parts fabricated off-site than originally intended, but progress will be made. My plans were to start moving forward in October. January is when it will actually take place.

Here at Starduster we are working on personnel to start the process of building stock for all standard Starduster items. The first part of the new year will be spent preparing new catalogs directed at the Starduster Too, and Accessories. Our catalogs will then be added to web pages. We will also be working on the 51% Kit evaluation by the FAA for the Starduster Too. We plan on having a good year.

Start planning for the Starduster Open House in May. I talked to the weather people and they tell me the weather will be perfect, winds will be from the east, north and south on Thursday and Friday, dead calm on Saturday and a very strange weather phenomenon will have winds blowing from Oroville to the north, east and south on Sunday. They say it is caused by the singing of a ballad,

something like, "Stardusters in the Sky." Someone was so motivated after hearing the song, they flew into a dark cloud and bumped into the weather people. They took interest in the song and want to hear the Starduster pilots singing loud and clear in May.

I am still working on my V-6 in the Starduster Too. Doing well until I decided to finalize the nose bowl and narrow the cowling. This required changing from tuned headers to a different type of exhaust system. The tuned headers were too wide to fit into new cowling. Short tubes were the direction I went. Still working out the bugs. With the narrow nose bowl performance is everything hoped for and then some. One of my early goals for next year is getting the front of my Starduster painted to match the rest of the machine. Was hoping for 300 hours this year, only got to 150. In 2000 will shoot for 450 hours. One of the other goals I have set is to visit every airport within a 200 mile radius of Oroville.

I want to thank Clay Gorton and Glen Olsen for the excellent work they are doing on the Starduster Magazine. I want to thank all those people behind the scenes who have helped Starduster keep going and moving along. I also want to thank Bill and Brenda Clouse and wish them happy holidays.

We at Starduster wish you happy holidays and a very rewarding new year.

Les and Mary Homan

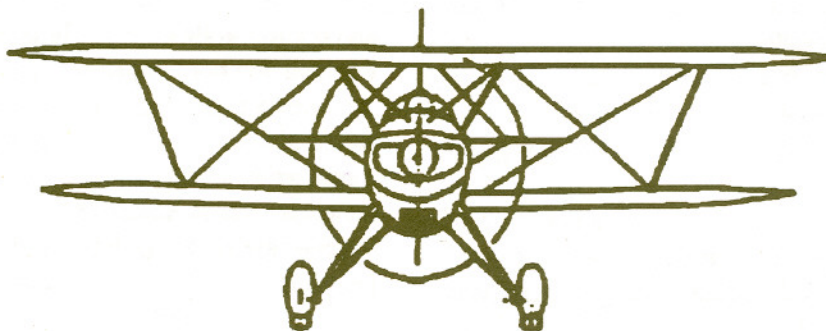

Correspondence

Starduster Corp. 22 August, 1999

I just wanted to say Hi and thanks for the great magazine. Keep up the good work. Enclosed is a picture of Jerry Rhinehart's N160JR (yellow) & my N507RG (orange) at Sentimental Journey in Lockhaven, Pennsylvania. We are having a great biplane summer in northeast Ohio. Thanks,
Bob Griffin, Warren Ohio (See photo, page 19)

People— 17 August, 1999

The last thing general aviation needs is another magazine filled with pretty pictures of completed aircraft. How about getting these 'Duster guys to send in pic's of "how they did it." Dummies like me would find it more useful than looking at a plane that was built with a checkbook. (SA100—up to instrument panel. Closest SA100, 190 miles round trip, just to take a peek!!)
Craig Phillips, Rancho Mirage, CA

Sirs: 20 August, 1999

I would like to subscribe to the Starduster Magazine as per your ad in Kitplanes Sept. 99. Enclosed is my check for \$18.00.

I purchased my Starduster I in January 1997, N290WM. It is hangared at Gulfport-Biloxi Regional Airport at Gulfport, Mississippi.

Sincerely,
John Majure, Biloxi, MS (See photo, page 19)

Hi Clay— September 9, 1999

Here are the latest photos of the Acroduster we got at Oshkosh. These were taken last Monday, the 30th of Aug, or thereabouts. As you can see, Gary works fast. He painted it this past weekend. So now, the fuselage is done. Now, Gary is working on the wheels and brakes, and is getting the aluminum primed and painted.

I'm off for points south, now, and I'll be in touch when I get back.

Chris DeBaun, Lakeville MN (See photo, page 21)

Dear Clay, October 16, 1999

Once again I am in your debt. I just received the October issue of Starduster Magazine and was

very pleasantly surprised to find myself mentioned in it. Thanks very much to you and to Don for mentioning Lynn and myself. It was quite nice of you to do so.

However, I must point out one error. The aircraft that I (and my mates) had restored was not the Stearman. We had restored a rather rare version of an F-86-F Sabre. The aircraft was part of the "Q" project at the Pacific Missile Test Range for the U.S. Navy in China Lake, California and was in very poor shape and scheduled for the "junk heap" when several of the members of the museum of which I am a member (Air Classics) found the aircraft and had it trucked back to our airport at Aurora, Illinois where we restored the aircraft (static only) to its original condition.

Once we got into the restoration, it was found to be an RF-86-F, which I understand is only one of 18 such models ever converted, and one of only three left! The Stearman (or should I say "StearDuster"??) you mention is the aircraft that had been restored and was purchased by us at Heritage Air Corps, Inc. in April of this year.

Again, thank you for your inclusion of Lynn and me in the magazine. We both have already made our reservations for next year's show at Oshkosh and Wautoma and really look forward to seeing you fellows again. We really did enjoy it. Take care and "keep 'em flying."

Sincerely,
Randy Cordray, Naperville, IL

Ken—

Regarding the October issue of the Starduster magazine I feel that I must bring it to your attention that the photo on the front cover was taken by myself, Mr. Wayne Bundy of Romsey, England, and not Mr. RJR Cardy. The Photo was taken over Popham and not "Papham" as printed. I feel that I am owed a printed apology in your next issue and I would also like to be sent two issues of your next magazine so that I can forward one to the pilot of the plane. Yours Sincerely,
Wayne Bundy, Footner Close Romsey Hampshire, England.

Mr. Bundy,

We do apologize for any errors in the write-up about the beautiful photo of the Starduster shown on the front cover of the October issue of the Starduster magazine. We're glad to recognize authorship of the photo. It was a significant addition to our magazine.

Editor

Hello Les: November 4, 1999

I've been out of touch with anyone at Starduster since Bill passed it on. The first week in October saw a rebuilt N26TK fly with a 300+ HP IO540. After their initial flight, I reshimmied the horizontal stab to parallel with the longerons and she trimmed almost perfect to hands-off.

We did notice flutter on both aileron actuators at 140 MPH (these are streamlined tubing) so I am swapping those out for a round thick wall 5/8ths diameter 4130. I'm enclosing a couple of photos.

Jeff Hardy (See photo, p. 22)

Hi Clay— November 8, 1999

Here are a few more pictures we took last week. I finished the upper wing except for nailing on the final half of the leading edge. I'm waiting for Gary to decide how he wants the pitot tube to look. The original leading edge was metal, but I decided to go with plywood. It's easy to bend, it won't oilcan or dent, and it's easy to do. I will need to replace all leading edges, because even though the wings weren't damaged (except for the one top and one bottom panel), all the leading edges are badly corroded. Since I have the plywood, I'm going to use that. I'm back in California again, so I won't be able to work on the bottom wing until after Thanksgiving. Once I get started, I can have it pretty much done in about a week.

Big milestone was reached on 30 October.

Gary and I got up early, pushed the Acro out of the garage, tied her to the bumper of my truck, and started her up. I got to do the honors, because Gary needed to look for leaks, and be ready with the fire extinguisher. At 8 am, we woke up the neighborhood. I didn't feel guilty: they wake us up with their stupid lawnmowers all the time. Anyway, it only took six blades, and the engine roared to life. Gary was busy taking pictures, so it was I

who found the first leak. He had missed an oil fitting on top of the engine somewhere, so I had oil everywhere. The back of my truck as well as my hair and face were covered. Thank goodness I was wearing my glasses! When I shut down the engine, I had to go jump in the shower and left Gary to clean up the mess. I wasn't mad, though—I now have very soft skin!

So next comes the cowling, which Gary is working on even as I type. I'll keep you posted.

Take care,

Chris DeBaun, Lakeville, MN

(aka C5Babe) (See photo, page 21)

Hi guys, November 21, 1999

I'm really enjoying the building discussions on the bulletin board. I just completed new instrument panels for my SD II and will get them powder-coated next week. Since I have everything exposed I'm replacing and rerouting all lines and wiring. Once this is complete I will reassemble and hang the engine, hopefully for spring flying.

I stopped in to Mandan, ND last Saturday and had a nice visit with fellow Starduster II owner Logan Holm. Even though we were unannounced, he came right out to show us his airplane. Will forward pictures I shot with new camera. Also talked with Bob Scarlett from Bismark who has just completed his IO470-powered SA300. All that's left is to hang the wings and fly but he plans on waiting until spring.

Enough for now. Happy flying for those of you living where it's still warm enough.

Dan Benkert, Rapid City, SD

Dear Glen, November 17, 1999

I thought you might be interested in the airport owned by Bud Fritchley. This is a private airport, Hepler Airport (43IN), at St. Wendal, Indiana, 9.5 miles NW of Evansville, Indiana (Evv). It has a 2600-foot grass runway with a cut-out in the tree line on the west end and buried wires on the east end. East end has a displaced threshold due to a hangar location.

We have a Starduster SA300, single place Pitts, Spacewalker II, Aeronca 7AC, three other experimental aircraft and four factory built aircraft. All are tailwheel, but for one Cessna 172.

Bud and I own the Starduster N84MM. Keith McCutchan just bought the other Starduster, N85RC, from Randy McKinney. I checked him out and he is now flying it.

Bud or I would be glad to give anybody a ride

that is interested in building or buying a Starduster. There is also a single place Starduster about 8 NM east of Evansville at the Booneville Airport. Gene Glackman, Evansville, Indiana

How it's done in South Africa

Paul Roberts, Wakerville, South Africa

Hello to all you Acroduster and Starduster pilots and builders out there. I recently subscribed to the Starduster Magazine and shortly afterwards received a letter from the Editor asking me to write an article describing my Acroduster experience with you. This recognition, international as well, pleased me no end!

I've always had a passion for aeroplanes, which started when I was about seven years old when I was allowed to sit in a Spitfire MK16 at the local R.A.F. base of Sealand in North Wales. That memory still lingers years and numerous Airfix models later and working, by this time, in "Darkest Africa."

I arrived at a pilot training centre at Rand Airport, which is situated very close to Johannesburg one Sunday morning with the great idea of learning to fly. That particular training centre eyesore was short lived. The centre's manager, on seeing me arrive on my motorcycle, gleefully announced to everybody that a Hell's Angel had arrived to fly, fortunately or unfortunately, my wit being somewhat sharper than hers made me ask if her broomstick was jet powered as I couldn't see a prop! Her husband/Manager, probably understandably, did not take too kindly to this comment, the end result being their losing my business and me looking elsewhere.

I discovered a small flying club about 60 km from Johannesburg which had a single Piper 140 and at most three students. I didn't realize it at the time, but taxiing the 140 from hangar to ramp, after the flight, washing it and the hangar talk, formed my appreciation of what grass roots flying is all about. My first solo soon followed, and was celebrated with the other club members at a hangar party held at another airfield about 100 km away. In the excitement of my first solo I had forgotten

that petrol was rationed and not sold over weekends. A V-tailed Bonanza donated the avgas for my motorcycle to get me home.

My next major achievement was to get on the wrong side of the examiner during my PPL test. The pre-flight was duly carried out and the examiner stood on the wing, took off his jacket, which he tossed onto the back seat. Unbeknown to me he had left his pipe on the roof the 140. Taxiing to the holding point, I saw him looking under the seat, rummaging in his flight bag, etc. He finally remembered where he had last seen the object of his search just as I was about to start the engine run-up at the holding point. I had to taxi back to the ramp to retrieve the pipe, which was now in two pieces and quite useless. The test now became a real ordeal for me, as it was generally believed that if he lit his pipe on the cross country phase of the test then you stood a good chance of passing. Now that he couldn't smoke I didn't know until we had returned to the club house that I had indeed passed.

Club membership by this time had increased to about 15 students with the result that the 140 was hardly ever available, so back I went to Rand Airport, this time to a different pilot centre. I completed the night rating and converted onto the usual types, C172, C182, Arrows, etc. I did quite a lot of flying across to Sun City, a casino complex, about an hour's flying time away. I learned a lot during those trips—everything from weather variations to looking out for baboons on the ramp and runway.

It was during this time that a friend mentioned that aerobatic training in a Pitts S2A was being offered by two South African Airways pilots. I did the basic course and then moved onto the advanced course, which I found to be great fun. However, students were not allowed to perform the take-off and landing owing to insurance clauses,

despite my offering to pay for any additional insurance; and not getting any response, I realized that my own aircraft was the answer. Here began my involvement with the Acroduster.

I saw an advertisement in a local flying magazine for a wing kit for an Acroduster II. Needless to say I ended up buying the first part of my dreams, which consisted of six spars, numerous lengths of cup strips and a couple of sheets of plywood. Thinking back, what appealed to me most about the Acroduster was the overall look of it—in my humble opinion, far prettier than the Pitts!

Next step was to build the jigs for the ribs. This done, laminations of the spars followed. It dawned on me that although I could now start to assemble the wings and centre section, to continue I had better start ordering the 4130 tubing for the fuselage, undercart, tail, rudder, etc. Time went on—the wings built, fuselage frame in the jig, the engine mount ordered from Starduster, which when it was received lined up with the fuselage and to my satisfaction and delight matched perfectly. Next came the under-carriage construction, until finally I had enough parts which when all assembled actually looked like an aircraft. Flying wires from Starduster were then fitted and again, as with the engine mount, were found to be a perfect fit. A great deal of credit must be given to the designer.

The next major scoop was the acquisition of the engine, a Lycoming IO360 A1A. It was only after starting this project that I discovered that 180/200 hp engines were very scarce in South Africa. Finding a suitable engine was a worry until one day, quite unexpectedly, I received a phone call asking if I was interested in an IO360. After negotiating a price a quick trip to the bank secured the deal. The engine has now been fully overhauled.

Home built/experimental aircraft in South Africa do not qualify for a Certificate of Airworthiness. They are instead placed in a category called LSI. The Experimental Aircraft Association and Aeroclub of South Africa both have inspectors who are approved by the Civil Aviation Authority to inspect and sign off work done on home built aircraft. One area which they are very strict about is the welding which we are not per-

mitted to do ourselves.

A major obstacle in building my Acroduster has been the poor Dollar/Rand exchange rate, which is presently R6 to the dollar. I can only think of one other major set back during the building which was when a radio, two tail struts, two tail flying wires and the tail wheel and spring assembly were stolen out of the workshop.

Future schemes: I have recently ordered material and parts from Starduster which I should be receiving via DHL. Hopefully by the time my ramblings here go to print I should have received, and once fitted to the airframe the entire fuselage, undercarriage, cabanes, tail, and rudder assembly will be taken to Pretoria, approximate 150 km away, for its final welding inspection and signing off.

Thereafter the engine will be reunited with the airframe for engine-to-cockpit link up. Then final assembly, covering and painting. A local Pitts builder/owner reckons my Acroduster to be +/- 70% complete now. To quote Gary Shunk of Oregon, definitely a light at the end of the tunnel.

Building of the Acroduster aside, I hope to be attending ground school for my Commercial and instrument license and ratings. The ground school lasts for eight weeks of night school, Mondays to Fridays, or nine weekends. The commercial exams are a major hassle in South Africa, the syllabus covers everything from plotting (the navigator's job?) To the P9 compass. The only P9 compass which I have ever seen was in a Tiger Moth and it was fitted below the instrument panel. Once this has been done, it will be onto the simulator for +/- 20 hours procedural training, followed by some flying in a Beech Duchess to prepare for the flying test which has to be done in a twin, as single engine commercial and night flights are a definite no-no in South Africa.

If all goes to plan, I should have the Acroduster ready to fly about the same time I get my commercial license, which will leave just two minor problems, which are finding a job with decent pay and hangarage for the Acroduster.

I hope my ramblings have been an informative contribution to the magazine and of interest to all. I will attempt to make any future contributions more specific in nature.

How it's done in New York

Dave Millikan, Akron, NY

I've only made two trips around the patch so far, but everything went well. I'm not going to use the old 'joy to fly' phrase, I'm too old for that, but it was satisfying after 30 years of building. The aircraft is a straight forward Starduster Too with an O-320 150 HP (out of a Callair sprayer) with a Hartzell 76" constant speed prop. The engine has 1000 hours and I tore it down completely, had the cylinders reworked with new valves, had the crank inspected and converted to constant speed, all new bearings, camshaft, pistons, and rings; so its essentially overhauled, with overhead mags and carb—it's running fine so far.

The gear is in the moved back position and I built a 7" stretch where the fire wall was for small baggage and battery space. (see photo in Jan 98 issue of Starduster magazine). I tried to find the drawing of the engine mount, but to no avail. I did find the lord mount drawing and it shows the prop flange 40 5/8" forward of the firewall (180 hp). I measured my prop flange at 38" forward of the fire wall plus the 7" stretch, so I'm out 45" from the original firewall. You can check the conical mount drawing and see if I boogered those dimensions.

The whole purpose of all this is; with the engine location where it is, and the 30 lb or so heavier prop, the CG and tail weight came out very nice—(70 lb on tail wheel). The cabanes are welded on and not removable. My empty weight is about 1120 lbs. Yes, I added a full panel, one extra wall thickness on the engine mount, cut down military bucket seats and some other foolishness. Used Stits 90x (no longer available) and only a minimum number of coats of Poly Tone. Before first flight, among other things, I chocked it and ran full throttle for 60 seconds. I found a small hill on the airport and did another full throttle check in a nose high attitude.

9/1/99, 8:15 am, the wind was 4 mph right down runway 7 at Akron, NY. Did a thorough run-

up, took the runway and opened the throttle, checked for 26-2700 rpm ok, started to ease the stick forward and it lifted off (don't need any fwd stick, huh?) checked the air speed going thru 80 (so that's good for approach), rechecked rpm—still good—settled back and climbed maybe 1000 fpm. Went around the pattern and reduced power some for a low pass for photos (100 ft & 100 mph) everything cool— well, cyl hd temp was near high green at climb power. Came around again and set up for landing, using 80 mph, reduced power (probably too aggressively) checked height, whoa! I'm there, did nice flare and squeaked it on fully stalled, not even a hint of a bounce—it was flat through flying. Probably can't do that again for months.

I have noticed many 'Duster Too write ups where the builders have no flying experience when they buy the plans. I was more fortunate, having a com smel & sea, CFI and 1600 hours (including 800 in 4 eng recip in the Air Force) I was inactive for long periods due to lack of funds but it seems to have come back easily. My prep for 1st flight was a 1.5 hr biannual in a skyhawk, one flight in a Starduster Too with an O-320 with one landing and one take off. That Starduster Too was started in '68 with mine and does not have the engine moved forward or a constant speed prop. The A&P owner flies sportsman and took all the elevator balance weights out, removed the starter and bolted a 30 lb steel block in its place and has another 10 lb steel disc behind the prop. With a fixed pitch prop the acceleration is sluggish compared to mine. (That's why when I was ready to raise the tail, it was already flying, unlike the other Starduster Too.)

For any other long suffering souls—keep building, your day will come. I never had any doubts about finishing (short of health problem), but I never expected to be so old (70). (See photo, page 20)

Persistence Pays Off

By Bob Caravas, Grants Pass, Oregon

Keep up the good work—the magazine is great. I look forward to every issue. Enclosed is a picture of my Starduster Too which was finished in August of 1997. (See photo page 21) The picture is mainly sent to show what can be accomplished if you have the patience and the will to succeed. I'm speaking to a lot of builders out there that have not finished their projects and may be getting discouraged because of various reasons like job change, lack of money, divorce, etc. Don't get discouraged people, there are many ways to complete your projects.

I'll tell you a little story about the lengthy building time of my Starduster Too. In 1947 I received my private pilots licence. After that I went after my commercial ticket—which I never finished because of some of the reasons that I stated above. I won't go into my personal reasons—dropped out of flying for quite a few years. I met a friend through having coached a little league baseball team—his son was on the team. After one of the games was over conversation led to him stating he was going home to work on his airplane which was a Great Lakes Biplane that he was building from scratch. Well! That lit up a spark in me. After a nice visit of his plane he invited me to an EAA chapter meeting, which I didn't even know existed at that time. Well, after a couple of meetings I was hooked. The flying bug never leaves, fellas! Once you get bit, that's it!

I went to an air show in Watsonville, California near where I live in San Carlos, and there it was—right inside the main gate—the most beautiful biplane I had ever seen. It was Harry Dellicker's orange Starduster Too. Well, after talking to him for over two hours, I came home and told the wife I was going to build an airplane—she looked at me and said, "Are you crazy or something? What do you know about building an airplane?" I said, "Why not? Other people build them—I don't see why I couldn't." At this time in my life I was working as a certified welder for a company that was building various airborne components for the Navy and Air force. My hobbies at this time were hunting and fishing, and I paid for those trips by

doing taxidermy work for others.

The business was getting a little slow and expensive. I decided to sell all my equipment and mounts. Did OK, and started buying material from Starduster Corp. It wasn't long before I ran out of money. What do I do now? I had to find some other source for money. Couldn't take money out of my pay check, that was out of the question. Too many mouths to feed, too many shoes to buy for the kids. Oh, yeah, and the mortgage on the house. I thought for some time. What do I know best that I could make some money in my spare time to pay for this airplane? WELDING! Of course—that's it! I purchased an old arc welder and a friend of mine rigged it so I could TIG weld with it. Before long I was welding parts for other EAA members and their projects. I worked eight to ten hours on my regular job—came home after work and welded sometimes into the early hours of the morning. Money started coming in—more material was purchased for my Duster. Worked on my airplane when I could in between money jobs. It was slow going—two years had passed—the company I was working for went on strike in 1975. I never went back—started working for a company that was building sail wenchers—boats that were racing in the America Cup yacht race. Worked there another eight years. The company was sold to an outfit in Australia. I didn't want to go there. I was in a dilemma—no Job, bills had to be paid, mortgage was still on the house, food still had to be put on the table. Work on the Starduster came to a halt. What do I do now?

I told the wife I was tired of losers and I was going into business for myself. I acquired a small loan and purchased a better welding machine—top of the line. Went out to various small machine shops and became a vendor for certified welding—the word got around about my type of work and my little shop started making money. I obtained a welding job from Frank Christen on the Eagles Biplane when he was just starting to produce the airplane. There I started "AERO WELDING" which is still going today, although at a semi-retired pace. Still love to weld on airplanes.

In 1988 I retired and moved to Grants Pass, Oregon. Here I was able to build a shop/hangar on the Grants Pass Airport. Purchased a nice home—the mortgages are all paid and the kids are away and making their own families. The wife and I are in our golden years enjoying retired life.

The Starduster was finished here on the field and flown for the first time in August 1997. It was a beautiful day. I had a friend of mine, Hal Averyt, test fly the plane. I was not going to do it as my flying had gone to pot over the years. The Duster flew beautifully! It was a joy that I can't express. Those of you that have flown yours know what I'm talking about. You just have to experience it your-

self. In essence this is what this letter is all about. Not about my accomplishments, but about what you can achieve by persevering. Fellas, don't give up on your projects—find a way, something to finance your dreams. Mine took twenty years to finish—but let me tell you it was fun, it was education, it was exhilaration in the end. So it takes a few more years—you'll never regret the effort. Every once in a while I have to scrape the bugs off my teeth, laughing as I fly my beautiful Starduster around the sky. Don't give up!

P.S. It's also kind of nice to walk away with a trophy, like I did at Merced.

Saga of 4226Y Continues, V-6, part III

By Les Homan, President, Starduster Corp.

Changes taken place since last magazine include finalizing the cowling and noseowl. It has reduced the flat plate area approximately 1 square foot. We do not have it painted yet. The exhaust system consists of individual short pipes. Sounds like a P40 warming up. Not as loud as expected at full power either. Not any worse than the Lycoming with four long straight pipes. Will have some work to finalize exhaust pipes. The prop will need to be fine tuned again.

At this point I have no questions regarding performance. According to records kept with the 200 hp Lycoming, I am equal to its performance. Only one thing I am not sold on yet and that is the prop. Ground adjustable is the only way to go but where my concerns are is in consistent climb and cruise performances. I would like to think that with a similar amount of fuel on board, temperatures, air speeds, engine RPM's and altitudes, results would be the same. Sometimes at 85 IAS climb shows as 1,000 FPM. The next time it may be 1,500 FPM. At 95 IAS climb it was showing as 1,800 FPM. These are sustained climbs from ground to 1000 AGL. The best so far is 2,500 FPM at 90 IAS. As far as indicated air speeds at

altitude, 2,500 MSL, the same problems are evidenced. With engine at 3,600 RPM, IAS will vary between 105 and 120, other conditions being similar.

One of the problems experienced is EGT has a variation of 200 degrees between low and high cylinders. I was ready to put the modified TBI manifold on to replace the aftermarket unit. Jess Meyers with Belted Air Power contacted me last Friday with a possible fix. I tried it over the week end and it made a big difference. Another problem experienced in changing from the 3 into 1 tuned headers to short straight pipes relates to fuel flow. I could not bring the EGT's down to an acceptable level. On the way home it dawned on me the problem is increased fuel flow but the float is set too low. As mixture is richened the valve opens but low float limits fuel available, resulting in a small EGT drop but then leans out. This will be fixed this weekend and further progress made.

We will be providing an information pack after first of year with pictures, performance reports, list of parts where to get each item. Let us know if interested in finding out more.

Where Do You Put Your Eyes When You Land a Starduster?

Clay.....,

To land a Starduster, I look at the world over the left front corner of the cowl probably 92% of the time from whenever it is I lose sight of the runway by tipping up the nose of the beast in preparation for landing. On final, if I need to, I slip with the nose to the right so I can see the runway to the left of straight ahead, straightening out before crossing the fence and still looking as far forward as possible on the left side of the cowl. I slip maybe 40% of the time.

Verne Reynolds, Mt. Vernon, Washington

Glen,

I have flown my Starduster Too N76GS for 15 years now and every landing is still an adventure. (You may recall my airplane has two American Indians on each cowl side and the phrase 'American Adventure' on the vertical tail).

When turning final my eyes alternate between the airspeed meter and the field ahead. On final approach this alternating procedure remains the same—although I apply upwind rudder and skid to keep the field in sight. When I am sure the airplane is proceeding down the centerline I release pressure on the pedal and look straight ahead, cut any remaining power, picking out runway lights or any other cues on each side to stay in the center. To enhance the peripheral vision I found it helps to sit up straight at this moment while my eyes are focused straight ahead at nothing in particular.

I don't think I'm the only Starduster pilot who feels it necessary to play a Spanish Cadenza on the rudder pedals during the rollout.

Also, I found that a radio headset and push-to-talk switch are very helpful when calling traffic on final so that I can concentrate on the above landing sequence.

Max Bennett, Buffalo, New York

Hi Guys,

Glen, you provoked a lot of thought with your question of (how do you land a Starduster?) I suspect that the answer depends on how you were trained, how much experience you have, how your airplane was built and configured, and what your

local flying conditions are. Before getting my Starduster II, my tailwheel time was limited to Cubs of various vintages, Citabrias, and a little right seat Beech 18 time. I felt that since I had a few hundred hours instructing from the back seat of Citabrias, I should make an easy transition. I of course was humbled when it didn't happen the first flight.

I had previously done three landings in an SA300 that I was looking to buy and things went well. This one had a canopy and you sat high enough in the back seat to have excellent visibility. Mine is open cockpit and you sit as low as possible to avoid the downwash off the top wing. Both had the standard bungee gear so I lack a comparative reference here.

I can state with some certainty that wider is better when choosing a runway for landing practice. Density altitude will also play a part as it causes increased ground speeds as it rises.

Little biplanes have lots of drag so I keep a tight pattern which allows a nearly continuous turn from downwind abeam until touchdown. I level the wings briefly on base leg to check final for other traffic. I approach touchdown holding a modest slip into the wind and straighten out for a three-point landing regardless of crosswind. My aircraft won't do a true full stall landing with power off so there is full control authority available to counteract wind situations after touchdown.

I found that this is much easier to accomplish if you can see over the nose so when I get all three down I simply use enough forward stick to raise the tail and take a look. Once I acquire the center line I use rudder and aileron as needed. By this time I have slowed and am stabilized enough to allow the tailwheel to come down and keep it there. Done smoothly, it looks like a wheel landing but has less risk and gives me more consistency. As always, a go-around can be your best friend. If it doesn't look and feel right, start over. With the power-to-weight ratio most of us enjoy, another circuit takes only a few minutes and sure beats trying to recover from a bad landing.

Dan Benkert, Rapid City, South Dakota

Dear Glen,

I began landings by sitting up straight—eyes forward—peripheral vision, etc. Things were OK but not great as it was hard to develop any consistency. Most landings were wheel landings or more accurately stated—“tail low wheel landings.” Once in a while I pulled off a fairly decent three pointer. I also used to land with too much speed which I think is a fairly common occurrence among new Starduster pilots.

Then I began to slow down, pick my touchdown point at the end of the downwind and concentrated on assuming the 3-point attitude in my mind and tried “to make the picture a reality” through the flare to touchdown. On straight-in approaches I usually make several S-turns on final just to wake myself up and to be sure I have my proposed touchdown point nailed down. I really don't know what my final approach and landing speeds are as once I start the above procedure I don't look at the instrument panel—I estimate my over-the-fence speed to be about 75-80 mph.

Now I alternate between wheel landings and three-pointers. Sometimes I get a good three-pointer but truthfully many of these are “tail very low wheel landings.” This is ok with me if it's a smooth and controlled arrival.

Having said all the above, I must confess that for the last couple of years I no longer worry about keeping my head straight, eyes forward, peripheral vision, etc. I had been going in and out of some small strips and basically hung my head out the side of the cockpit to keep the runway edge in sight when I needed to see. (You're asking a real tough question by the way).

To try and sum this up I would say speed control is the most vital component once a person has developed the ability to “know where the runway is.” I think, however, that in the beginning the “eyes forward” technique is appropriate. I certainly do not have a definitive answer about what makes a good landing, but I do know that the more I practice them with a full roll-out as opposed to touch and goes, the better my landings are.

Interestingly, on my Alaska trip with Oscar and Les there was so much going on that I didn't have time to worry about landings. Wheel landings in strong winds down the runway and cross con-

trolled into the wind when it blew from the side. The more I think about this the more convinced I am that speed appropriate for the conditions is a primary ingredient for successful arrivals. Number two is picking your spot and visualizing what you need to do to pull it off.

This certainly seems like a shaky response . . . but landings are difficult to describe. I look forward to reading what the other Starduster guys have to say.

In closing let me say that for me a great exercise has been to let it roll out to a full stop—no brakes—and get used to the amount control action required to get thru the 50-40-30-20 mph slowdown. My other often used tactic is the go-around—sounds corny but if it doesn't feel right going in the first time I set up again and this gives me a few minutes to critique what was making me uncomfortable. I hope this helps.

Bob Pisani, San Mateo, California

Glen Olsen, Starduster Magazine,

I should ask how you land a Starduster Too consistently well every time. I would like to know. I hold power until I am close to the runway. If I can keep 80 mph on final I can see the far end of the runway. I look out to the left to see the edge of the runway during the landing flare. If I let the speed bleed off a few seconds before I start back pressure on the stick I will make a soft landing.

I use a forward slip when landing on short runways. A left slip works better for me than a slip to the right, which means a landing with a cross wind from the right is not pretty to watch.

If I let the speed drop below 80 mph on final the nose gets too high and the runway is out of sight. I will then skid or slip until the runway is back in sight. I then am holding too much back pressure on the stick and do not have enough speed for a good flare. A navy carrier landing is then the result—no bounce, but I have tested the landing gear shock cords again. This is not to say I have never bounced on landing, I have. I am still learning to land my Starduster after 715 hours. Best regards.

Matt Kerr, Bay City, Michigan

Dear Glen,

You couldn't have picked a worse subject to ask me about than landing. I aim for the numbers and when I'm pretty sure I will reach them, I cut the power and hope for the best. Well, maybe not quite that bad, but I really don't have a technique that works for me all the time. It seems that each time the conditions will be just enough different that what worked last time isn't going to work this time. What I do try to do is remember what the angle looks like while taxiing. If I see the same picture at touchdown and concentrate on making sure I get the stick all the way back it usually works pretty good. If the tail wheel touches just prior to the mains and you get the stick back, it will stay on the ground, otherwise bounce, sometimes very high. The airspeed I try to trim for is 100 mph and from that point on rarely look at it, just try to judge the rate of descent for the distance to the runway. My Acro handles real well on the ground and am sure this has helped things.

I don't like straight in approaches in the Acro or even a standard approach for that matter, especially if I am #2 or 3 to land. Traffic permitting I like a close-in sort of carrier type keeping the runway in sight and rolling out over the numbers. Can't always do it though.

A couple of years ago while in Portland visiting my daughter, Dave Baxter gave me a ride around the area in his Starduster. We left his home base and flew to a nearby little airport where his son worked. His take-offs and landings were great, even wheel landed it for me. I have only tried wheel landings a couple of times with little success. Whatever Dave's technique is, that's the one I would promote.

We missed seeing everyone at Wautoma again this year, but rolled our reservation over to next year. Hope to make it then. Sincerely
Bob Hammond, Tonawanda, New York

Dear Glen,

Thanks for your letter asking about landing techniques. This got me to thinking about the way I landed my Starduster One, so last weekend I went on a trip from my local airport to find out.

My local airport has a control zone and a mix of traffic—light aircraft, helicopters and business jets, so the circuit pattern is orderly. Although it

sometimes seems to stretch into the next county. The main hard runway is 03/21 and about 6000' long. After landing away at a small grass airfield and also a private strip I returned to my local airport circuit where the traffic was using 21 right. After spacing myself from traffic—the other two aircraft in our formation— (I don't like turbulence) I turned right on to final at about 700'. Wind 240° at 6 knots, temp. 50°F.

Power is 1500 - 1700 rpm (I have a fixed pitch propeller) and adjusted to keep the numbers in view, speed about 90 mph.

As I round out, having viewed the runway since turning final, looking out the left side of the cockpit, I hold off at a height of 6" to 1' above the runway, throttle closed and looking as far ahead as possible along the runway. This usually results in a smooth landing, but not always. There is no trim system and the aircraft is nose heavy without power and sometimes I bounce. The aircraft runs straight on landing. If it bounces, I leave the stick where it is unless I manage a really good bounce which needs power to sort out. Touchdown is 75 mph. These are indicated airspeeds about 15-20 mph above actual speed due to static source within the fuselage being pressurized.

The runway is exited at the first available turn-off unless ATC says to land long or taxi to the runway end keeping your speed up. That's it.

Finally, I don't have to side slip because visibility from the cockpit is good enough to see everything going on.

Hope you can use some of the above for the magazine. I thought the last issue went very well.

Best regards,

Harry Mackintosh, Wimbledon, England

Hi Glen,

Here's my two cents worth on landings with limited experience in a Starduster Too. As soon as I turn final, I check the wind sock again and will have already established a pattern speed of 80 IAS. I'll line up the aircraft straight down the runway centerline and set up a normal descent rate with emphasis on aircraft attitude. I'll maintain 80 IAS for wheel landings and use 70/65 IAS for three point.

On touch down, my eyes are focused down the runway using my peripheral vision for the sides.

I'll notice if I drift to one side or the other and make a go around, if needed, at this point.

It depends on winds what type of landing I make. My Starduster prefers wheel landings the best. I can land in a three point and can lift the tail to a wheel landing attitude, which is good for runway visibility, if needed. I'll keep the tail up until the airspeed bleeds off and the tail drops. After that, I pull the control stick back to keep pressure on the tail.

I've talked to pilots who swear by wheel landings and others who prefer the three point. I guess it's what you're comfortable with, but be sure you can accomplish both.

Luckily, we have a long and wide runway here, which is great for learning to land tail draggers and I needed every bit of it. I prefer to let the aircraft slow down with little or no braking and be careful of a changing wind direction when taxiing off the runway.

If there are strong x-winds, I go hangar flying and listen to pilots tell their stories. Each year they get better and better.

It's good to read what the expert pilots have to say, but there's nothing like gaining first hand experience by getting out and flying yourself. May your takeoffs and landings be of equal number.

Dave Mercer, Klamath Falls, Oregon

Dear Glen,

When touching final, I like a 10° to 15° angle to the centerline and threshold to the runway so that by slipping to the runway it is always in sight to the point in front of flaring. During the flare I straighten the longitudinal line with rudder and spot any drift with aileron, wing down into the wind, or side slip and then let the aircraft settle slowly and increase the pitch to the three point attitude for a three point touchdown, being careful not to balloon or touch before the three point attitude is achieved.

I focus on the runway on the approach, then on the first third, and then out about 40 to 80 feet using my peripheral vision and sitting straight. A power reduction is made as soon as I feel the runway is made. I also feel, if you focus on the one side or lean to that side, you may drift to that side. I use the cabane struts and the flying wires to judge the three point attitude and the height above touch

down. At touchdown I use the rudders for directional control and if necessary differential braking. Remember if you exceed tailwheel steering limits all you have left is rudders, differential braking, power and possibly an aborted landing.

I do not make long straight in approaches at slow speeds as the aircraft's nose will block the forward visibility and possibly other traffic. Using a higher airspeed will lower the nose for better visibility but this may cause floating and possibly ballooning because of sensitive elevator control.

To achieve a correct airspeed for power-off three-point landings I use 1.3 to 1.4 times the stall speed. This will normally give two to three hundred feet of floating before touching down. Remember airspeed indicators may be plus or minus ten mph in error.

With wheel landings, I use plus five to ten mph higher airspeed than the normal approach speeds for three-point power-off landings. I also may carry a little power to maintain a more tail high touchdown. A more horizontal attitude will require more airspeed and will give a better view of the runway, but a faster touchdown. I use a little nose down trim to help adding forward pressure on the control stick as the main gear touches, and to keep the tail up. This creates negative lift and prevents increasing lift and possible adding to a bounce. When the tail wants to drop I lower it by reducing forward pressure and when the tailwheel touches I apply back pressure to the stops to increase the tailwheel weight and effectiveness for tailwheel steering. If back pressure is too abrupt it may cause the main gear to leave the runway because of elevator sensitivity to airflow.

In my Starduster the three point attitude is reached before the control stick up against the rear stops. If you come back to the stops, it will always land tailwheel first and then the main gear. This is not a bad situation for an off-airport landing because it is touching down at the slowest speed, full stall, and the aircraft is through flying.

For narrow runways, I prefer wheel landings for better forward visibility. This may require more runway due to higher touchdown speeds.

For short runways I use full stall and minimum to no float airspeeds and I am ready for an aborted landing if required. You do not always have to land.

In cross winds the Starduster has sufficient rudder to make three point landings in fairly strong crosswinds. In gusty winds a wheel landing might give you more control and visibility during touchdown. If the need for wing down in a crosswind requires rudder to the firewall I will look for another runway that is more aligned with the wind.

All landings are easier on a grass runway than on hard surface runways. Most of my flying is from a grass runway, but I go to EVV and OWB quite often which have hard runways. Sincerely,
Gene Glackman, Evansville, Indiana

Well, Glen, you have opened a can of worms this time!

1. For years I would three point the following craft—Aeronca Chief, Champ, Cessna 140, 170, Piper J-3 Cub, Stinson S/w big tail and PA18 Super Cub and Starduster II-spring gear. In later years I went to wheel landing the Super Cub.
2. After buying Starduster II 70JH, I would three point all the time, but about two years ago found that wheel landings are safer and less stress on the tail wheel and spring and clips. The airplane did a 360° on the runway after springs or clips broke!! No damage to craft but it makes old pilots' hearts beat faster.
3. When I would three point I could not see very well being 5'6", so wheel landing I have great vision all the way to landing stop! So, down base at 95, turn final at 90 and 85 mph over the fence. Touchdown at 80 mph, and stick forward until tail comes down easy, and on go-around the airplane has flying speed at touchdown for safe go around, not so the three point stall speed. Thanks,
Jerry Acord, Wathena, Kansas

Dear Glen,

Following is the technique I use in landing my Starduster. As I roll into final I am trimmed for 80 mph, prop goes to high rpm, mixture is leaned to 50% to minimize plug fouling.

I usually try to use a fairly high approach in case of power failure, with the airplane in a slight slip with the down wing into whatever crosswind is present. This seems to give me a much better view of the runway, especially if I have a passenger.

At the flare I pick up the runway edge and at

touchdown full back pressure is applied as soon as all three wheels are firmly planted.

Hope this will be of some help. Keep up the excellent work. Kindest regards,
Kenny Ware, Eatonton, Georgia.

There is no substitute for practice. Practice, practice, practice. Learn to be in control of the airplane at all times. Make it do what you want it to do. During flight instruction landings are taught to be at a specific altitude and location, start a turn here, airspeed at XX plus or minus 1 MPH. For learning purposes and normal flight this is the way to go. What happens when the learning is over and the prop is standing still and all you have is one small field to put it in? If well practiced, not only in standard landing patterns, but in all other conceivable landing configurations, you put it in the field, step out, and thank yourself for hours of practice.

Practice flying the pattern as originally instructed. Practice landing from forward slips, from right and left slips, from a high short final, fast, slow, cross winds, no winds, strong winds, cut power in pattern and put it on the numbers, practice at different airports, touch down on left wheel, right wheel, right to left, left to right, make a landing pass with one wheel on runway and drive part way down a runway. Make it do what you want it to, do not let landings be a happening where you are not in full control.

Handling the rudder pedals. When taught to fly we were taught to use pressure, not movement. There are times when pressure immediately leads to movement, caught in prop wash from another plane, gusts, Etc. Rudder pedals are no different. The Starduster Too has a large rudder. When you move the rudder pedals, something is going to happen. Reactions are not overly quick as in smaller more aerobatic aircraft. At all times you use pressure, not movement but you have to be instantly ready for movement.

When are the best landings made, on a dead calm day or a slightly turbulent day? If you said a dead calm day and you are having lots of problems with rudder pedals there is a good chance those problems are self caused. If you said a slightly windy or turbulent day you are probably doing ok.

What happens on calm days is that very little rudder pedal movement is required and it is very easy for aircraft to be drifting in a direction, a correction is made, (over correction) and then a correction in the other direction, (over correction) and the dance continues. On windy days you know some movement will be required, you are prepared and expecting it and landings work out better. If you are making good landings on calm and windy days, you should be writing this and passing on your ideas.

Visibility, a hurdle to cross. After my first few attempts at landings, semi-controlled bounces to control tower height. Lots of time was spent sitting in aircraft on level surfaces, doing high speed taxiing with wheels on ground and low passes to the runway to get a clear picture. For me the left side was far better as a reference and things were more clear. As windshields and glass prescriptions changed so did landings. Practiced to consistency good landings and then not being able to hit the ground. Major problem seems to be judging actual distance above ground. Six inches or six feet, I have witnessed full stall landings from both heights. Visibility is different from front seat and back. S-turns are required during ground movements to prevent running over such items as the gas trucks, small Cessna's and other assorted ground clutter. When flying long cross countries I always take a direct look at the ground when down low, on final or short final. This gives me a direct reference and improves landings.

I look at landing in two phases. Phase one is getting to the runway and leveled out just above it. Phase two is letting the speed bleed off until the tail is low and then gently moving lower until the main gear touches. I then rapidly move the stick forward about a 1/4". This places my main gear on the runway and by holding forward stick the tail will remain up until slow enough it comes down. I then pull stick back full. Pressure on the rudders and slow so a turn can be made off runway. Sounds easy and with lots of practice it is.

Phase one. If I was to make a normal landing I would slow to 100 MPH on base and maintain until over the fence. On short final, threshold under me, 80 MPH would be the goal. I would then work at flaring and stabilizing approximately 12" above the runway. The goal is to place the craft parallel to the runway, at or below 80 MPH, speed bleed-

ing off. Night landings are made the same way except power is added and 80 MPH held until wheels are in contact with the runway. The critical thing here is practicing until you can get down to approximately 12" above the runway and fly full length of field. Try it at various speeds. Start at a comfortable speed, before control effectiveness erodes, 80 or 85 MPH. I have practiced between 100 and 60 MPH.

Phase two. Once you are stabilized and flying parallel with the runway you let the speed bleed off. I do mostly wheel landings. My goal is to let the plane slow down, tail starts dropping, just before it touches to do a 3-point landing. I want the main wheels to touch and I go forward with the stick. When doing 3-point landings I just hold the stick back longer and slow down until the plane stalls. Main problem I have is judging the exact height as this happens. I either am several inches, feet, yards, miles in the air, or I hit the ground with something and bounce. Doing wheel landings I still bounce from time to time but just set it up and try it again. Sometimes power is required. The distance the stick is moved forward will vary with different landing conditions and aircraft. You might want to set your plane up level, measure prop clearance and spend some time sitting in it to get the perspective. If you have a nose heavy aircraft and good brakes you can get the tail up if forward stick is over done. For cross wind landings I just put the wheel down into the wind and plant that tire. I maintain about 80 MPH until wheel is firmly on ground and all is under control. Then reduce power and let the other tire settle.

I will not guarantee this is the proper way or the best way to land but it has worked for me. Some words of caution. When landing with wind behind you either do a full stall or get the tail low, keep it there and do not touch the brakes. Better idea is to land into wind. When you go forward with stick to hold tail up, don't pull stick back and slam tail down or keep it extremely high with full forward stick and when the tail quits flying it will slam down all by itself.

Remember, practice, practice and more practice. Way to cheat—lower air pressure in tires and practice until every landing is perfect, air tires up until hard and practice until every landing is perfect, lower air pressure in tires to soft condition, and go show off.

Les Homan, President, Starduster, Corp.

Even More Words

from, *Sport Aviation*, Nov. 1999, *Letters to the Editor*, p. 6

In October's Flights Ops, "More Words on Landings," I agree with the author about the moronic ditty: "... two types of retractable geared airplane pilots, those who have made a gear-up landing, and those who will." This is a fatalistic attitude that may conceivably contribute to a wheels up landing.

However, I disagree with him about the common notion that a landing is only as good as the approach. If you arrive at the runway at the right speed, right track, and right altitude, you have it made. How you got there is totally immaterial. What if you botch your pattern and final approach and your mind is programmed to call it off and suddenly you have to land because of a real or perceived emergency? You might do something stupid. What happened behind you is as about as useful as the runway behind you or the exhaust fumes you left at cruising altitude.

When flying with either of my two sons, occasionally I purposely mess up the approach to see what they are going to do with what I leave

them. We practice recovery from unusual attitudes, so why not practice landing from an unusual approach?

Kent Tarver, LaCanada, California

You make a good point that practicing the unusual, such as attitudes, is a good idea. But consistency is the key to safe flying, and when landing, that means flying a consistent approach.

There are, however, different ways to fly an approach to landing consistently. A few suggestions are power-off from abeam the touchdown point, over obstacles, and descending in a spiral from some altitude above the runway (when the tower gives the okay, or the pattern is clear, of course)

*These can be "unusual" approaches, and practicing them to proficient consistency could saved a pilot and an airplane. But where safety's concerned, the prudent solution to a less than perfect approach to landing is a go around—
Editor.*

Note: As may be seen above, no two landing procedures are exactly the same. We would like to continue this column in the next issue, to give all

the rest of you guys a chance to tell us how you ever get that thing on the ground in one piece. Write to us! Ed.

Starduster Open House—Oroville

The first Starduster Open House in the new Millennium is scheduled for the Oroville, CA municipal airport (OVE) for the third week-end in May—May 19-21. *This is something worth planning for!* The event is co-sponsored by the local EAA Chapter that provides food and entertainment for the event. You'll have the chance to participate in a fly-in breakfast, aircraft judging, perhaps some amateur aerobatic competition, and much more.

We would like to encourage those flatlander pilots who have some trepidation about flying over (or through) the mountains, to bite the bullet and experience the beauty of some spectacular reference points that can be seen without leaning out of the cockpit. For additional information on how to get through the mountains with no problem, contact Editor, Glen Olsen.

An Acro II Partnership

By Leah J. Radford, Somerville, Tennessee

Just after the sun comes up on Saturday morning, two grown men can be found, sneaking out of the house, to go play at the Fayette County Airport in Somerville, Tennessee. That is, if Dr. Mike Finan can convince his mothers-to-be that they can wait a few hours to have that baby! His partner-in-flight, Sol Radford, doesn't have to convince anyone that he and Mike are flying the Acroduster on a Saturday morning. That's because Sol has been flying planes, every time he could, since he was thirteen years old.

The plane they are currently flying is an Acroduster II. This particular plane has an IO540 260 hp Lycoming engine with a Christen inverted oil system. It cruises at 165 mph indicated air speed at 23" mp and 2300 rpm.

Mike was born and raised in the Little Rock, Hot Springs and Jonesboro areas of Arkansas. A serious student, with a great sense of humor, he got a medical degree and then a law degree at the University of Arkansas at Little Rock. He holds licenses in medicine and law in Tennessee and in Arkansas. He spent a year in the Air Force Academy before his marriage to Dana, in 1969. Mike and Dana have a son, a daughter, a grandson and a grandbaby on the way. Mike's practice at the Brownsville Women's Clinic, in Brownsville, Tennessee, keeps him busy delivering babies at all hours of the day and night. He is also the Haywood County Coroner. Dana and Mike raise Portuguese Water Dogs and have had great success in and out of the show ring.

In 1992, Mike broke his hip. Sitting still for the first time in years (and his brain not crippled a bit), he decided the next degree he wanted was one with a little attitude and altitude. He had solo'd in Hot Springs, Arkansas in a Cessna 150. He got his Multi-Engine in a Baron. He has logged time in a Cessna 172, Cessna 182, Baron V35, Bonanza A36, Aztec, Comanche, Cherokee 180 and in gliders. Mike has logged about 1,000 hours total time.

After a while, Mike decided that flying straight and level was boring. Looking for a challenge, he decided to learn aerobatic flying. Mike trained in a

Pitts S2B and in a Super Decathlon.

Sol, born and raised in Memphis, Tennessee, has been a commercial artist at United Rubber and Die, Inc. for the past twenty-five years. He is married, with two sons and a daughter. Everyone knows, however, that his life-long love is planes. He got his first plane ride when he was eight years old. It tickles us to hear that he was scared to death and cried the whole time, because for the past 35 years, he has been flying planes, talking about planes, buying planes or watching planes (or thinking planes) twenty-four hours a day.

He got his start, at the age of ten, when his mother brought him to Wilson Field on the weekends. It was there that he met the man who would be his flight instructor, drinking buddy and life-long friend. Jack Foster, who taught hundreds of people how to fly and who must have seen something unique in that ten year old kid. He gave him odds and ends jobs at the airport, took him up in a Citabria 7KCAB and turned the plane, and a young kid's world, upside down. Sol says, "Jack thought everyone should be able to fly a plane as good upside down as right side up." Sol credits Jack as being "the biggest reason I like aerobatics. I never would have learned if it wasn't for him. It is a lot more challenging to do than flying right-side-up."

On his sixteenth birthday, Sol solo'd seven different planes. By age seventeen, he had his private license and by eighteen, he had his Multi-Engine and Instrument ticket. He spent some time working for Jack Adams Aircraft Sales in Arlington, Tennessee. "That's where I really got to fly all different kinds of airplanes." Sol worked for Jack Adams, off and on, for twenty years as well as working with Jack Foster, who had a Citabria dealership for a while. Since that time, he has flown every plane, with a piston engine, that Piper, Beechcraft, and Cessna have built, and is checked out in a B200 King Air. His favorite twin engine is a Grumman Widgeon.

Sol spent some time competing in aerobatic competitions in the early 1970's and did some air shows for Continental Air shows in Menomonee,

Cont' on page 23



Starlett N73KG, John Russell, San Antonio, TX



SA100 N290WM, John Majure, Biloxi, MS

SA300 160JR, Jerry Rhinehart, Warren, OH

SA300 507RG, Bob Griffin, Warren, OH





SA300, N147DA, David Allen, Huntington Beach, CA



SA300 N11DM, Dave Milliken, Akron, NY



SA300, N49BC, Bob Caravas, Grants Pass, OR



SA300, Chris DeBaun, Lakeville, MN

SA300, N26TK
Jeff Hardy



SA300
Logan Holm
Mandan, ND

SA750
Sol Radford &
Mike Finan
Fayette County, TN



Wisconsin, but preferred to just “mess around.” At the time, he was “messaging around” in a Pitts S1C. Just for fun, he also flew the Prototype Decathalon (N9020L) with Gale Bishop. One year, Jack Foster made a deal with Bob Brown, President of Champion Aircraft Corporation. Sol got to fly the forerunner to the Decathalon (N5143T) for the entire year. It was a parasol wing, open cockpit, two seater with a 180 hp motor and a constant speed propeller. It was never put into production because pilots got cold in the open cockpit in the winter, Sol believes. Sol later owned a Super Decathalon with a friend.

Here is where the two worlds came together. Sol was teaching aerobatics in the Super Decathalon at the Fayette County Airport. Mike, having a little training under his belt, came into the Fayette County Airport to rent the Super Decathalon. Sol rode with him to check him out.

That might have been the end of the story. Mike and Sol were having fun in the Super Decathalon and may never have moved on, except for one small problem. The fella who owned the Super Decathalon with Sol had to relocate to Arkansas when his wife got a job that was too good to pass up. The partnership was dissolved and the Super Decathalon was sold.

Sadness reigned in Fayette County for a while. Mike and Sol were not content to simply talk about flying. Mike made a bargain with his wife. She got a house built (quickly), and Mike told Sol to start looking for “muscle biplane.”

At first, Sol & Mike were considering a Pitts S2A or S2B. Sol started talking to people, in person, on the telephone and on the internet. “I was calling anyone who would talk to me.” Sol says. Somehow, he ended up talking to Bill Clouse and then to Glen Olsen. The Acroduster II appeared to be a reasonable alternative to the Pitts. The price was better, yet the performance seemed to be equal.

After calling people everywhere, he found an Acroduster II in Southern California. It had a factory-welded fuselage and a 260 hp engine. Another round of calling ensued. Everyone that Sol talked to at the factory was familiar with the plane, because they had worked on it. Sol told Mike to buy it. Mike agreed, so they arranged to have the plane flown to FYE, sight unseen.

“It turned out to be a good choice.” says Sol. “It has a lot of horse power. It’s fast, responsive and looks good.” The artist in Sol likes the long lines of the Acroduster II. He likens the Pitts’ appearance to a pregnant guppy because of the shortness of its lines. The Acroduster II has an elliptical wing that Sol likes the shape of. “The whole plane is attractive.” The paint, a light lime-green color with white accents, is very visible from the ground when the plane is in flight. Mike says he likes the plane “because it’s fun to fly!” Both pilots like the Acroduster II’s solid build. “It looks factory-built, not home-built.” Sol says. “No scrimping and the tubing is heavy.” The plane weighs about 1200 lbs.

Landing a tail-wheel is dicey for those with little experience. Sol, who logged many hours with Jack Foster before Jack’s death in 1998, has tried to pass his knowledge and experience on to new pilots, in much the same way that Jack taught him. Sol describes his landing technique as follows:

“I was trained by an old WW2 Navy Pilot. He taught me to fly the way he was trained by the USN and that means tail-wheel first or tail very low. He seemed to like it best when he could see or feel the back wheel on the ground before the mains.

I started flying a S1C when I was seventeen years old and never had any trouble with it. Twenty-nine years later, I find myself landing the Acroduster the same way. I fly the pattern at 120–130 mph and turn base to final at somewhere around 110 mph. I try to cross over the end of the runway a little over 95 mph (I think, but I don’t ever pay much attention at that point to the speed). I make a shallow turn so I can see the runway the whole time. I never lose front sight of the runway until I roll the wings level. I put my head back on the headrest and look straight ahead. I pick up both sides of the runway in my peripheral vision and do what I have to, to keep it going in a straight line.

I think the key to it is, when you roll the wings level over the end of the runway, the airplane is going straight. If the speed is close to being right, it’s on the ground soon after. Don’t quit flying it until you shut it down. Jack always told me “You fly the airplane. Don’t let the airplane fly you.”

Right after he bought the Acroduster II, Mike found landing the plane to be difficult, mainly due to the inability to see the runway through his forward vision. Sol, knowing that Mike would

improve as he gained confidence and experience, rode with him a few more times. Sure enough, Mike's landings improved. It seems that Jack Foster's lessons are going to teach more pilots than he knew.

Mike and Sol are currently building a DR-109. With Sol's assistance, Mike would like to enter some basic competitions. The Acroduster II, along with the new, high-performance monoplane, will enable him to gain the experience necessary for competition.

Sol is currently managing the Fayette County Airport on the weekends and flies the Acroduster II when the weather is good and when the mood strikes him to "hang around upside-down." Mike comes out to the airport every chance he can. He has flown the plane to visit friends and relatives in Pine Bluff and Jonesboro, Arkansas. On Saturday mornings, if the weather is good, and the babies hold off, both pilots can be found at the Fayette County Airport, just after daybreak. Sometimes, if you look quick, you can see them right-side up!

Stardusters In The News

Dave Millikan's Starduster Too, N11DM, is featured on page 93 of the November 1999 issue of *Sport Aviation*. Ron, who is from New Lebanon, Ohio, has had the plane under construction from 1968 until his first flight on 1 September, 1999. Congratulations, Ron, on the perseverance that has paid off in a beautiful Starduster. We wish you

many hours of happy flying.

Not only was Donald Fauth's Reserve Grand Champion Starduster Too, N147DA, mentioned in the September 1999 *Sport Aviation*, but recognition of the award won at the Arlington Fly-in has also been given in the January 2000 issue of *Kit Planes*, page 42. Congratulations again to Don Fauth.

Nothing New Under the Sun or Move over, Dick Rutan

(The following was excerpted from *Popular Mechanics*, October 1923, p.525)

Planes run by music roll without aid of pilot

Without passenger or pilot, airplanes have been made to operate by means of an electrically controlled roll of paper perforated in the same manner as a music roll. With this device a plane has been started on a lone 20-mile flight, attained a

height of almost a mile and a half at the end of the third mile, released a dummy bomb, circled for several miles, descended to 1,500 feet above the ground, snapped a photograph, and finally returned to its home station and negotiated a safe landing.

Tech Tips

So You Want To Align Those Wings Just Right??

By Glen Olsen, Salt Lake City, Utah

The leveling device that I am using is a sure way of properly setting your wings. I don't know who came up with this idea, but it sure works great. I made my device out of metal, but it can be made of wood, aluminum or whatever you have handy.

The first thing is to make sure your airplane is level. Align the top wings first.

Photo #1 shows the first station to place the leveling device, which should be as close as possible to the butt rib. After fitting the jig to the wing, loosen the C clamp and level the bubble on the upper arm, and then re-tighten the C clamp.

Keeping the C clamp tight, move the device

to the outer part of the wing, as shown in photo #2. Then bring the slider arm towards you to make a snug fit.

For the Acroduster, shim the upper I-strut as necessary to align the bubble. For the Starduster, if you have built your I-struts to plans, the top wing will not require any adjustments.

For the lower wings use the same process as for aligning the upper wing. For the Acroduster shim the lower part of the I-strut—front or rear—as needed, to level the bubble. For the Starduster, adjust the lower rear adjusting bolt as needed to level the bubble.

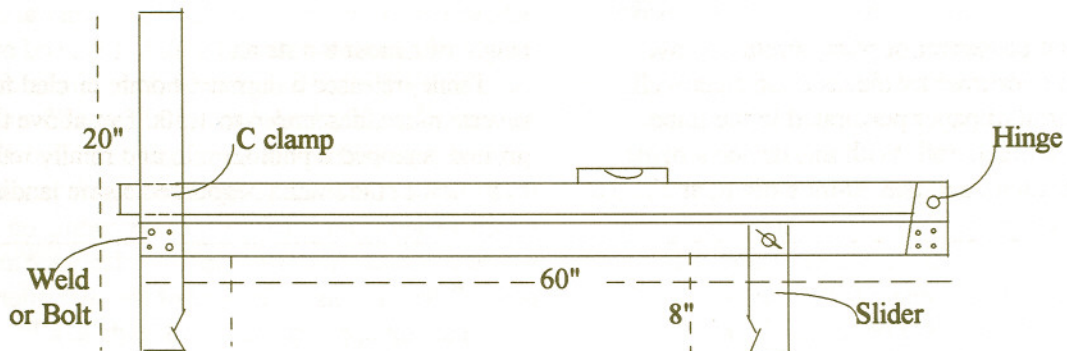
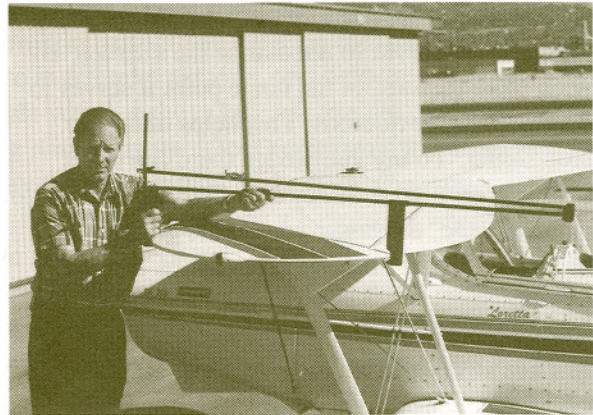
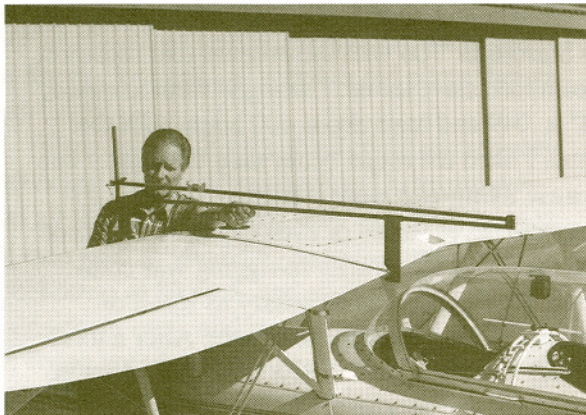

Starduster Too Slave Struts & Aileron Hinges/Bearings

Les Homan

Question:

Slave struts, do I install the new forward-of-hinge-line type or the old behind-the-hinge-line type? Do I need to remove the old behind-the-hinge-line type and install the forward-of-hinge type? Can I install spades to help my roll rate on the original behind-the-hinge-line type slave struts? Can I install spades on the forward-of-hinge-line-type slave struts?

Answer:

The Starduster Too was originally designed with slave struts behind the aileron hinge line. Slave struts are streamline tubing that connect the lower and upper ailerons. Hinge line is the aileron pivot point at hinges connecting the aileron spar to the rear wing spar.

Why is there a question as to rear and forward mounted? Flutter is the concern here. To minimize flutter, control surfaces must be balanced or close to balance. With the slave strut located behind the hinge line it adds weight to rear (heaviest portions) of ailerons and serves to unbalance the ailerons. By moving them forward of the hinge point it serves to add balance to the ailerons. This helps minimize aileron flutter. To my knowledge there has never been a case of aileron flutter on a Starduster Too. As I understand, the faster you go the greater the concern for flutter. I believe fabric helps dampen out flutter.

What this means is if you have the original style slave struts and they are working, do not worry about them. If you are re-covering or building your plane, consideration to move slave struts should be made. Another reason to consider moving locations is that spades cannot be used on the original rear mounted slave struts. They will continuously want to snatch and are very uncomfortable to fly. The forward mounted slave struts will accept spades and they work well. Rear mounted slave struts are installed at an angle and are made of streamline tubing. This tubing, if turned at the slightest angle will want to fly, resulting in a heavy wing or feedback into the stick. Ever notice the stick wanting to move and you did not do anything? The slave strut just

moved slightly. Several fixes have been tried—installing a welding rod on one side to prevent the flying, rubber or leather fill pieces at rod end bearings and use of round tubing in place of the streamline. There are many hundreds of these flying, and remember, if it isn't broke, don't fix it.

Forward mounted slave struts are mounted straight up and down and help prevent the flying part. There are problems with this type also in that although the struts still move some, they do not affect flying. One fix here is to install the rubber or leather rubbers in the rod-end bearings. We are working on a rod-end bearing for the lower connection with a double row ball type bearing to eliminate all movement. Another advantage of the forward mounted strut is it can be filled with lead to balance the ailerons completely. Adds weight to the aircraft, but flying is a dream. We are now installing a 3/8" x 3/8" x .035 square tube inside the forward slave struts. It adds rigidity and weight.

How do they fly? I have about 2,000 hours on my Starduster Too with the original rear mounted, streamlined slave struts. I changed them to round, 5/8" x .049 and have about 600 hours with the round. I liked the round better than the stream line because flying was more consistent, wing heaviness never varied or even existed at any time with the round struts after re-rigging was completed. Re-rigging was necessary as result of changing from streamline to square. After a total rebuild, recovering, etc. I now have 138 hours in my aircraft and another 30 in another Starduster Too with forward mounted slave struts. I do not believe you could tell the difference in forward versus rear mounted struts.

There are other things to be done to ailerons for major handling improvements. I went from the bushing type aileron hinges to ball bearings. Then from gaps in the leading edges and sides of ailerons which varied from 1/16" to 1/2" depending on where you measured, I set up 1/4" clearance at the nose of the ailerons to the rear of the spar aileron fillet. I set up approximately 1/8" gaps at all aileron-to-wing end fittings and have installed gap seals. Results are outstanding. Before, you could

get ahead of the stick as it was moved to right or left. It seemed like the pressure built up a little and at about the 1/2 way point would increase substantially. If you shoved it to the side fast you would get in front of the ailerons and have to wait for them. They now are very solid from first to full movement. You do not get ahead of them. Pressure builds evenly from start of movement to end. Roll rate has improved, but I haven't had a chance to time it yet.

Question:

How do I know if my aileron hinges are good or worn out? This also applies to elevator and rudder.

Answer:

Move the aileron up and down with your hands over each hinge. This movement is not an angular type of movement but a straight up and down. If you notice none or very little movement things are good. If you notice movement, 3/32" or more, there may be problems. Check this movement and document it as you complete or buy an aircraft. Check periodically and at each annual check with log book to see what wear has taken place.

Question:

I have a Starduster Too with the bushing type hinges and want to change them to bearing type. How do I do this?

Answer:

Very carefully check the edge distance as given on plans. If you have this much edge distance, or more, all you have to do is to drill the holes out to size below 5/8" (0.625) and ream holes to 0.625. One way to do this when brackets are still mounted on aircraft is to use a unibit and a hand drill. Make sure the hand drill is lined up so you drill straight through bracket, not at an angle. Break all edges and inset bearings. If they are not very tight remove them and use epoxy or T-88 to hold bearings in place. Coat inside of hole and outside of bearing. Push bearing in place and wipe off excess glue. Install washer between bearing and aluminum angle, on front of aileron spar, at both sides of bearings. This allows the bearing center bore to be locked into the aileron when attach bolts are tightened. You do not need to use the bend-up locking tabs as before. A nylon lock nut or castellated nut with cotter pin will work.

Starduster has the aileron bearings in stock at reasonable prices.

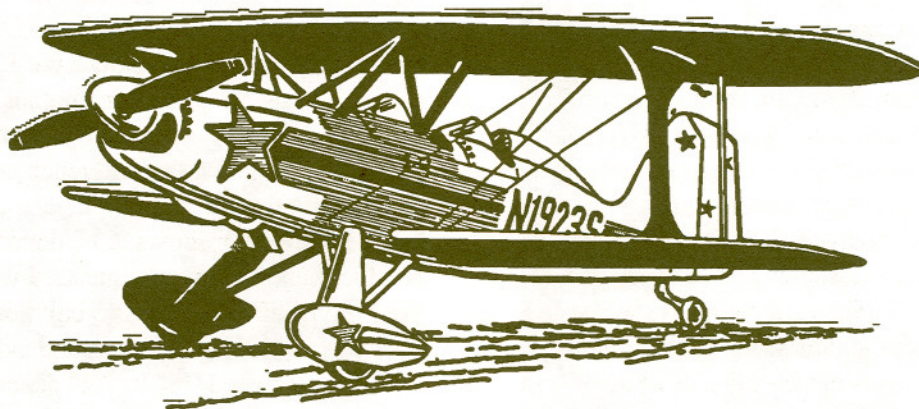

Seat Baggage Compartment for a Starduster

By Oscar Bayer

My two trips to Alaska and general flying over remote countryside in N490B convinced me of the value of storing at least a basic amount of survival stuff in my airplane at all times. Question? Where to put it? On my initial trip to Alaska in 1987 I found that some of the required equipment could fit into the headrest compartment, some in the baggage space behind the rear seat, some taped on the inside of the skin in the front cockpit, and even a little bit under the cowling behind the engine. By the time the 1999 trip came about, I had acquired a surplus Survival Kit Container which I substituted for my seat cushion in the rear cockpit and was able to fit almost all of the required items, other than sleeping bags, the survival weapon and a few other large things into this Kit. For normal day-to-day flying and Stateside trips, I am able to limit my survival equipment needs to those that will fit into the kit comfortably.

The nice thing about this particular container is that it fit very nicely into the Starduster TOO rear seat frame after removing the web that I had installed when I initially built the machine. The rear seat frame is 13½ inches by 15½ inches and the kit measures 13 by 14½ and fits quite snugly with the rear resting on the aircraft diagonal framework and the front on the seat frame. After modification, the empty weight of the kit with cushion is 8½ pounds, and with the stuff I have in it, it weighs 20 pounds even. I may have gone a bit overboard with the contents that I carry, but for those of you who would like to use the space for other things, have at it! The one big drawback that I found with this particular container is that it is not big for sitting comfort! The cushion is very thin at critical places and I have to use a supplementary pad. If you are a tall person, you may want to

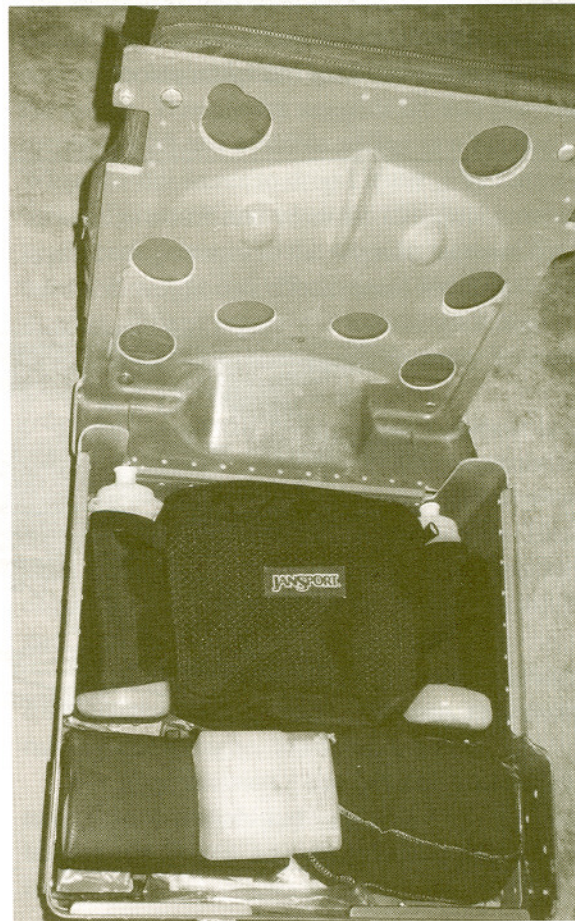
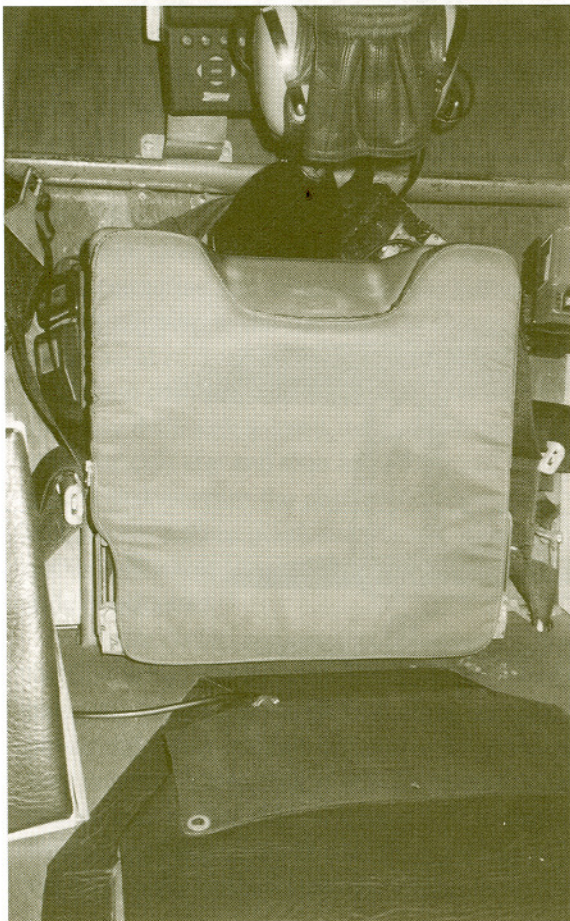

measure for height, particularly if you have a canopy. The only modification that I made to the Kit was to remove all the deployment hardware and everything else but the basic box and cushion. That is how I got it down to 8½ pounds. I recommend that you shop the Surplus Stores or on the "Net" for this particular item before doing any-

thing else, there are lots of military surplus survival kits out there, but this one fits perfectly!!

Survival Kit Container

Stock # Rh 1660-075-8105-1a 20

Rocket Jet Engineering Corp. Glendale, CA.

Part # 347000-3, Type RSS K-5, Type Seat A-5.

An Inexpensive, Positive Pressure Breathing System

By Steve Roghert and Fred Winberly

From *EAA Experimenter*, Nov. 1998



Rationale

The organic compounds found in epoxy and paints are toxic and it is highly likely that allergies or other conditions detrimental to one's health could develop. Respirator masks with charcoal filters absorb these organic compounds but they have a life span of approximately eight hours of continuous use. At this rate, things can get pretty expensive. Otherwise, the builder works without a respirator or with useless filters. How many people keep track of the number of hours they have used a respirator? Our goal, then, was to build a cheap, fresh air breathing system that you just turn on and use.

Materials

- 1 used charcoal respirator.
- 1 air supply:

- We have found two different fan/blowers to be quite satisfactory. One is a furnace-induced draft squirrel cage blower, 3000 rpm, Universal #JAIC119. The other is a bathroom exhaust fan. Specifically, a 70 CFM exhaust fan made by Nutone, model 685. It costs about \$20 from our local builder's supply store. NOTE: A word of caution about using air compressors as a source of fresh air. Some compressors emit tiny droplets of oil and these types should not be used.
- 1 air hose:
We found a 24-foot section of 1 1/2 inch flexible discharge hose for a sump pump (flotec, part No. 12-6) from the same builder supply store. Cost about \$6.

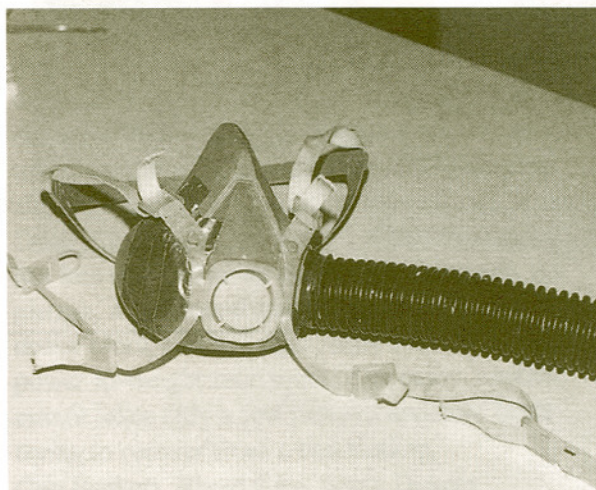

Construction

This is pretty straight forward. Remove the charcoal canister(s) from the respirator. If the respirator has two canisters, tape one opening closed. Connect one end of the hose to the face mask. We used duct tape in the two prototypes but anything that will secure the hose and make an air tight seal will do. Make something to funnel down the blower exit vent to the diameter of the hose you are using. Being real connoisseurs of quality construction, we cut a plastic yogurt cup and duct taped it to the hose and blower. On the other unit we used a PVC reducing fitting and duct tape. We also used tie-wraps to construct a belt-loop; that keeps the tension of the hose at your belt and not at the mask. You also need some type of filter to cover the air supply inlet. That keeps you from sucking in bugs and other stuff. We used furnace filters which are available in all shapes and sizes. Cut the furnace filter as necessary and fit to the air intake side of the air supply unit.

Quality Check

With everything connected, turn on the air

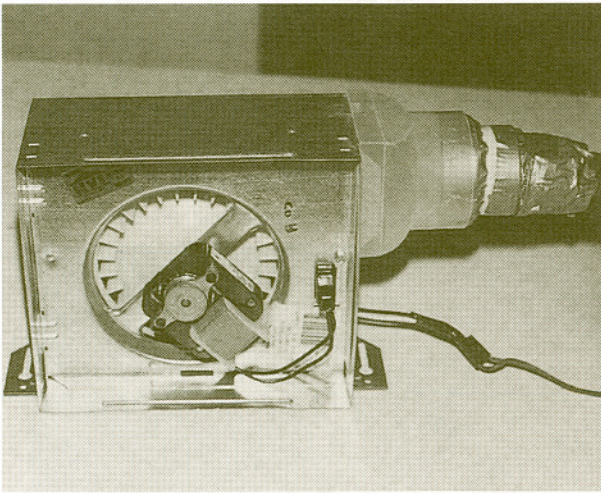

supply and hold the air mask up to your face. You should have air coming out of the exhaust side continuously, even when inhaling. This assures positive pressure in the mask to hold out the fumes. If it seems to be working correctly, place the blower outside the work area and give 'er the true test. Fasten the mask to your face in normal fashion, turn on the blower and open a can of something smelly. Bondo or acetone are ideal candidates. Hold the can close to the mask. If you can't smell it, the system is working.

Normal Operation

The air supply blower is placed outside the work area. Alternatively, mount it on the sill of a partially open window. But be sure that you prevent the room air from getting to the air intake. The hose is rolled out to the work area. Turn on the blower, put on the mask and enjoy cool fresh air while you build your plane.

Summary

In addition to assuring you are breathing clean outside air, room ventilation can be restricted to help make it easier to heat the work area. Of course, I guess there is a trade-off if you live in L.A. But this thing is so easy and cheap to make that every one of us should be using a fresh air supply. There are several fresh air systems on the commercial market today, costing significantly more than this one. I believe in a previous edition of *Sport Aviation*, one builder constructed a breathing system out of the blower side of his vacuum cleaner. We just wondered what could be done with an absolute minimum amount of time, effort and money. Good health is easy to lose but with a very small investment, the risk from toxic chemicals can be minimized so we can continue to fly, hopefully for a long time.

Safety

Transitioning to the Pattern

by Paul Novacek (AvianPaul@aol.com)

Ever found yourself confused about how to enter the traffic pattern at a non-towered airport? Of course . . . it's happened to all of us! In this article, an experienced CFI based at one of Florida's busiest uncontrolled fields describes a simple, safe, sure-fire transition technique that works every time.

How many times have you been approaching an unfamiliar uncontrolled airport and had difficulty determining the landing runway and how to enter the downwind leg? The decision as to which runway to use is often made in a hurry while preparing to land.

I have seen some situations of pilots using left turns when right turns are clearly depicted by the segmented circle. When these pilots are queried on the ground the common reply is that they thought all patterns are to the left at uncontrolled airports. You could imagine the results of two pilots trying for the same final approach from different directions. When was the last time you looked for traffic on an opposite base?

Clearly a transition technique from en-route procedures to traffic pattern procedures is needed.

By the book?

The Airman's Information Manual recommends that we enter the traffic pattern at a 45° angle into the downwind leg. But which runway is the best for the winds? Often an ATIS report from another close airport does not completely portray the local surface winds. And as Murphy's law has it, nobody is talking on the radio, and from three or four miles out the wind sock is just a little orange speck.

The procedure commonly taught has been to overfly the airport between 500 to 1000 feet above the traffic pattern and look at the wind sock or wind tee to determine the correct runway for the prevailing winds. The traffic pattern direction is also observed from this glimpse of the segmented circle.

At this point we know what runway and which way our turns should be, but now what? Some mental gymnastics are required as to which way to turn. Do I make a U-turn, supposing my entry is behind me, continue straight ahead and descend directly on the downwind, or fly the long way

around?

Without a unicom or other aircraft in the pattern, it is difficult to ascertain the correct runway for the winds and any non-standard patterns. Some pilots use a modified military overhead approach and may descend onto traffic that might already be in the downwind leg but not communicating. Or some pilots may fly away from the airport after confirming the runway direction and risk flying into a departing aircraft or noise sensitive areas.

Another scenario may entail being on the wrong side of the airport to enter the downwind directly, and needing to circle the airport some distance away at traffic pattern altitude. This may conflict with other aircraft departing at the same altitude, or cause an inadvertent excursion into controlled airspace.

A better technique

As pilots, we are always looking for procedures that are simple and effective. I have used a "transitional pattern" entry technique for many years with much success. This transition procedure borrows a little from the IFR procedure turn and a little from the military overhead entry procedure. The result is a technique that works every time and that doesn't require the usual mental gymnastics. Here's the procedure, step by step:—

- Fly directly to the airport between 500' and 1000' above the traffic pattern altitude.
- While directly over the airport (or a little offset so you can clearly see the windsock or wind-tee and segmented circle), determine the intended runway of landing.
- Turn to the upwind heading (i.e., runway heading) and fly away from the airport a comfortable distance (less than 1 minute), still above pattern altitude. To avoid very steep turns if a 180° turn is needed away from the center of

the airport, maintaining runway centerline is not necessary.

- Turn 45° in the direction of the traffic pattern (turn left for a left pattern, right for a right pattern) and proceed outbound a comfortable distance to maneuver (no more than a minute). Hold altitude to avoid any departing aircraft beneath you.
- Perform a 180° turn back towards the airport in the same direction of the pattern turns (left for a left pattern, right for a right pattern). This puts you on the correct 45° pattern entry heading. Start descending to pattern altitude and slowing to pattern speed while in the turn. This turning and descending maneuver will expose more of your wings to any departing aircraft thereby increasing your chances of being seen.
- Level off at pattern altitude before entering the pattern. Now you are on a 45° entry into the downwind, at the correct altitude and airspeed. The rest is standard traffic pattern procedure, always vigilant of any traffic on final.

Possible traffic pattern radio calls could be—

- Overhead at two thousand for runway 27.

- Upwind for runway 27 at two thousand.
- Outbound on a 45 for runway 27.
- Inbound on a 45 entry to the downwind for runway 27.

This technique is a good transition from enroute procedures to traffic pattern procedures, and can be used for almost any situation. Exceptions would be terrain or controlled airspace that may have to be avoided.

This entry technique keeps you turning, which increases your chances of being seen by other aircraft because of the large area of your wings against the sky. The technique also keeps you close to the airport in low visibility conditions or when unfamiliar with the airport.

I know that the main reason to fly is to get from one place to another quickly, and performing multiple turns takes more time. Yes, the transitional pattern takes a few extra minutes, but it's time well spent avoiding other aircraft. It offers one simple and easy-to-remember procedure that works for almost all situations. Statistics show that a good proportion of general aviation accidents are in the landing phase.

How's That Again?

This (reportedly) really happened at a non-towered airport in Northern California. The pilot of a Cessna 180 on amphibious floats, en route from Kentucky to Alaska, called for an airport advisory, and the Uni-

com operator issued the following: "Wind calm. No reported traffic. Use runway 32 or 14, your choice." The 180 pilot replied, "Which runway is longer?"

The Ten Biggest Lies About Piston Aircraft Engines,

by Mike Busch

Continued from Vol. 29, No. 3, July 1999

This article originally appeared in the March 1998 issue of Cessna Pilots Association Magazine.

Lie #6: The cooler the engine's oil and cylinder head temperatures, the better.

It turns out that the "cooler is better" notion isn't quite right. While excessively high temperatures are bad for your engine, low temperatures are no great shakes, either. Take oil temperatures. Most of our airplanes have oil temperature gauges that have a green arc running from 75°F to 240°F, with a red-line at 240°F. Now, 240°F is way hotter than we'd like to see. Keep in mind that the oil temperature probe is usually located at the place in the oil system where the oil is coolest, often near the outlet of the oil cooler. So if the gauge reads 240°F, the oil is probably hitting close to 280°F at the hottest point in its circuit through the engine. That's hot enough to cause petroleum-based oil to oxidize and break down at an accelerated rate. We've either got to bring down the oil temps, or change the oil very frequently.

On the other hand, oil temperatures lower than 170°F or so on the gauge present a different problem . . . namely, that the oil is probably not reaching the boiling point of water at the hottest point in its travel. Why is this important? Every time we shut down the engine, a slug of water condenses inside the cooling engine and runs down into the oil sump. If we don't get rid of this water the next time we fly, there will be a progressive water build-up inside the engine. That water will mix with the sulfur and nitrogen byproducts of combustion to form sulfuric and nitric acid. And that will start eating away at the innards of our engine. The solution is to make sure the oil gets hot enough to boil off the entrapped water, so that the resulting steam passes harmlessly out the breather.

Oil temperatures of 180°F to 200°F on the gauge are hot enough to get rid of this water, yet cool enough not to accelerate the breakdown of the oil. So that's ideally where we'd like to see our oil temperature gauge in-flight. What about cylinder head temperatures? The CHT gauge on a TCM engine usually has a green arc from 200°F to 460°F, with a red-line at 460°F. Lycomings gener-

ally have a CHT red-line of 500°F. Once again, red-line CHT is way too hot for optimum engine longevity. At those temperatures, the aluminum cylinder heads are vulnerable to cracking, and the exhaust valve guides are vulnerable to accelerated wear.

On the other hand, CHTs below about 300°F create another problem: lead fouling. Our engines operate on avgas that contains large amounts of tetraethyl lead (TEL). Even so-called "100LL" contains enough TEL to keep the EPA awake at night. The purpose of TEL is to enhance the octane (detonation resistance) of the fuel. Unfortunately, it also can cause lead deposits in the engine, particularly on spark plug electrodes and in piston ring grooves.

To prevent such lead fouling, avgas contains a "lead scavenging agent" called ethylene dibromide, whose job it is to dissolve excess lead and let it pass harmlessly out the exhaust pipe. However, ethylene dibromide doesn't do its scavenging job unless combustion temperatures are fairly high. That's why lead fouling problems tend to emerge when CHTs are below about 300°F.

Ideally, we should try to keep CHTs in the 350°F to 400°F range as much as possible. That's cool enough to keep the cylinder heads and valve guides happy, but hot enough for effective lead scavenging.

Lie #7: Aggressive leaning results in burned valves and detonation.

Fear of the red knob is one of the most pernicious areas of misinformation among general aviation pilots. Most pilots operate way too rich most of the time, and do so because of the mistaken belief that leaning will harm their engine. The result is usually trouble: fouled spark plugs, accelerated exhaust valve guide wear, and stuck exhaust valves. Lycoming has long authorized leaning to peak EGT at any cruise setting up to 75% power. TCM authorizes leaning to peak EGT up to 65%, and its latest recommendations even endorse lean-of-peak operation for many big-bore engines, pro-

vided the engines will run smoothly when operated that lean.

Contrary to popular belief, aggressive leaning doesn't cause burned valves. Most burned valves are the result of excessive valve guide wear or valve stem contamination. Aggressive leaning doesn't cause detonation, either. Most of our engines are incapable of detonation at cruise power settings, provided that we don't exceed CHT red-line or try to burn contaminated fuel. Furthermore, recent tests on Lycoming engines by ASTM revealed this fascinating result: detonation is most likely to occur at a mixture setting 11% richer than stoichiometric (i.e., substantially richer than peak EGT).

Lean as aggressively as the book allows. For Lycomings, that means peak EGT at all cruise power settings to 75%. For Continentals, lean to peak EGT up to 65%, 50°F rich of peak at 75%. For turbocharged engines, also limit TIT to 1600°F.

Lean during all ground operations except for engine start. It is particularly important to lean for taxi and runup. Since EGT is usually off-scale at idle power, the best method is to lean for peak RPM at idle.

Lie #8: It's bad to cruise at high manifold pressure and low RPM ("oversquare").

The old saw about never allowing MP to exceed RPM/100 is bunk! Fortunately, this one seems finally to be moving toward a well-deserved death, after decades of being accepted as Gospel by countless well-intentioned pilots.

TCM and Lycoming authorize cruise operation at 1 to 3 inches "oversquare" for most normally-aspirated engines, and allows 9 to 12 inches "oversquare" for most turbocharged engines. Check the cruise charts in your POH or, better yet, obtain the operator's manual for your engine.

Operating at minimum RPM and maximum MP (within the allowable envelope) actually helps your engine last longer. Low RPM operation provides numerous benefits: better cylinder compression, lower frictional losses, improved propeller efficiency, cooler-running valves, lower EGTs and TITs, and a quieter cabin.

Cruise at the lowest RPM and highest MP that the book allows for the percentage of power that you desire. You usually have several possible

RPM/MP combinations to choose from at lower altitudes in a normally-aspirated airplane, and at virtually all altitudes in a turbocharged airplane. **Lie #9: Continuing to fly an engine beyond the manufacturer's recommended TBO is dangerous, illegal, and could void your insurance coverage.**

Hogwash! First of all, it's important to understand that TBO is an actuarial figure . . . the manufacturer's best guess about how long a typical engine will be able to operate before needing an overhaul. Some engines won't make it. Other engines will sail past TBO in great shape and provide many hundreds of additional hours of reliable operation before teardown is warranted.

Think of published TBO as being similar to published human life expectancy. We don't expect all humans to live to that age and then keel over. Some will die before their time, others will outlive their children. Certainly, we don't arbitrarily euthanize people when they reach the average expectancy age! Published TBO has no legal significance for the majority of us who fly under FAR Part 91. For commercial operators under Part 135, TBO is theoretically "compulsory" because TCM and Lycoming publish their TBO figures in the form of a service bulletin, and Part 135 operators are required to comply with service bulletins. However, a Part 135 operator may apply to his local FSDO for a TBO extension, and such extensions are routinely granted by the FAA. For example, one company that operates a huge fleet of Cessna 402s (published TBO is 1600 hours) has FAA approval to go to 2400 hours before overhaul.

Your aircraft insurance carrier could care less whether your engine is past TBO. Your policy simply requires that your aircraft and its pilot be legal under the FARs. As we've seen, published TBO has no legal impact on Part 91 operators. Part 135 operators need to ask the FAA's permission before flying past TBO, but such permission is commonplace.

We recommend that you overhaul your engine when it gets tired, not at some arbitrary number of hours.

Lie #10: A factory reman is better than a field overhaul, because only the factory offers a true "zero-timed" engine.

While it's true that a factory rebuilt engine

comes with a zero-time logbook while a field overhauled engine does not, it's not for the reason you may think.

When you have your engine overhauled by Mattituck, RAM, T.W. Smith, Victor, or whomever, that engine retains most of its original parts, as well as its serial number, data plate, and engine logbook or other maintenance records. The overhauled engine you get back is legally the same engine you sent in, all cleaned up with lots of new parts.

On the other hand, when TCM or Lycoming receives a runout core from a customer, that engine loses its identity. The data plate is removed and destroyed. So are the logbooks. The case halves are cleaned up, inspected, and added to a big pile of reusable case halves. The crankshaft is cleaned up, inspected, and added to a big stack of reusable cranks. The same is true of camshafts, rods, accessory gears, and so forth. Those reusable parts become "anonymous" because they're no longer associated with any particular engine serial number.

Now, when TCM or Lycoming builds up a factory rebuilt engine (colloquially but incorrectly referred to as a "factory reman"), it pulls some "anonymous" case halves from one pile, an "anonymous" crankshaft from another pile, and so forth. When the engine is completely assembled, it gets a new data plate, a new serial number, and a new logbook.

The logbook starts out at zero time-in-service. Why zero? Because there's no other reasonable figure to put in the logbook. The case halves are certainly not zero-time, but there's no record of how much time they've accrued. The crankshaft may not be new, but there's no record of how much time is on the crank, either. And so on.

In short, the "zero-time" logbook that comes with a factory rebuilt engine in no way implies that the engine is "newer" or "better" than a field overhaul. All it implies is that the reused components in the engine are of unknown heritage . . . nobody knows how long they were in service prior to the time they were cleaned up, inspected, and reused in your engine!

Silence can be a problem even when VFR

By Alton K. Marsh, *AOPA Pilot*, December, 1999

Regulations regarding loss of communications focus mostly on flights in instrument conditions. Those rules are listed in FAR 91.185. But what if you're VFR? Can't that be a problem, too?

Rene Minjares of Englewood, Colorado, knows that it can. As an owner and instructor at Barnstormer Aero Services, an aerobatic flight school at Denver's Centennial Airport, he has had two radio failures. Each time, a combination of procedures from his civilian and military training allowed him to return to Centennial without driving the tower controllers crazy.

The airport lies under the Denver Class B terminal area, which offers no problem as long as the nordo (no radio) aircraft remains at less than 8,000 feet. Minjares first flies to an established VFR reporting point, and circles for a few minutes while squawking a 7600 transponder code. He then flies to the airport at 7,300 feet MSL, or about 1,500 above ground level.

He circles 500 feet above pattern altitude, dipping his wings back and forth in front of the tower, waiting for a green light-gun signal from the tower. The wing dipping was learned in military training (he now flies a Boeing 777 for a major airline). His procedure lets the tower know that while he is not part of the normal pattern, he is not an interloper who has stumbled into Class D airspace by mistake.

Obviously, a loss of communications while airborne in VFR weather is easily managed. When flying IRF, a number of rules come into play. The problem could be solved easily. For example, if you can receive but not transmit, controllers will ask you to respond with the ident button on your transponder. Or you can pick up that handheld transceiver (you have one, right?), and the problem is over.

First, let's look at a few questions you might have, especially if you got that instrument rating

some time ago. Do you still think that the proper transponder procedure for lost communications is to alternate the code between 7700 and 7600?

Wrong. The new approach is to squawk 7600 and leave it there. The controller will still know who you are. Nothing in the data block on the controller's radar screen will change, including your N number, if you start squawking 7600 instead of the assigned code.

Once the radios fail, the controller *anticipates* (an official term from the controllers' rule book) that you will do what you said you would do, and at the time you said you would do it. If you were cleared as filed and expected to arrive at the airport at, say, 10 a.m., follow the clearance and arrive as closely to 10 a.m. as possible. If the controller had put you in a hold and told you to expect further clearance in 15 minutes, then the controller anticipates that you will depart the hold 15 minutes later.

Let's look not at the rule book, but at what really happens. Tim Hardison, president of the Washington Center local of the national Air Traffic Controllers Association, was generous enough to provide some practical advice.

First of all, Hardison, a controller, will try calling you several times. He is used to pilots not responding on the first call. Then he will ask you to ident if you can hear him. Failing that, Hardison will ask another aircraft to try calling you. The next approach, one especially useful for general aviation aircraft, is to have a flight service station call you on the voice-capable VOR nearest to your position. If the problem is with an airliner, Hardison will ask another company aircraft to have the dispatcher send a text message.

Here are a few tidbits of real-world practice. You might think that controllers would call on 121.5 MHz. In practice, that doesn't happen very often.

Additionally, controllers at Washington Center don't experience pilots of nordo aircraft calling on handheld transceivers very often. It *is* common to receive a relayed message from a nordo pilot calling on a cell phone. Yes, use of a cell phone from an airplane violates Federal Communications Commission rules because it blocks cell phone frequencies for miles around the aircraft (unless it

is one of the new AirCell phones). But in an emergency, at least you can relay a message to a center or tower controller; but don't expect to be controlled over the telephone. In fact, Hardison said, you might wait until near your destination if you feel you must make an emergency cell phone call.

Communications failures are quite common at Washington Center, but not the kind you think. Radios are not failing; rather, pilots are getting lost among the frequencies when switching to a new controller. The solution there is to go back to the last assigned frequency, or call the nearest flight service station and ask them for a frequency in your area.

Real communications failures, in which the radios quit working, do happen. It has happened to general aviation aircraft approaching Dare County Regional Airport in Manteo, North Carolina—a popular vacation destination on the Outer Banks. That airport happens to be in a nonradar environment. What does Hardison do? He shuts down the airport. No one arrives or leaves on an IFR flight plan until the problem aircraft is down safely. Hardison anticipates that you will arrive over the airport while still maintaining your cruise altitude, before descending and making the approach. But he doesn't take any chances. When your aircraft comes within range, he blocks the airspace in case you start down. If you are still en route, and he doesn't expect that you would start a descent, he does not block airspace.

For the details, you can either curl up with a good regulations book and read FAR 91.185, or read the *Aeronautical Information Manual's* section titled "Two-way Radio Communications Failures." The ideal goal is to prevent the problem in the first place. That means investing a few (hundred) bucks in a handheld transceiver. Hardison said handheld communication is heard at Washington Center as "rough, but readable," and is better than none at all. An external antenna connection will greatly aid in restoring near-normal communications.

Finally, if you encounter VFR weather while en route with a radio failure, proceed VFR to the nearest airport and fix that thing. It's better than disrupting the system. You've been meaning to for weeks, right?

CLASSIFIEDS

ADVERTISING CLOSING DATES: MARCH 1, JUNE 1, SEPTEMBER 1 AND DECEMBER 1. CLASSIFIED ADVERTISING RATES \$5.00 PER COLUMN INCH, MINIMUM CHARGE \$5.00. MAKE CHECKS PAYABLE TO STOLP STARDUSTER CORPORATION. THANK YOU.

FOR SALE

Half share available in Starduster Too, 180 Lyc. Inverted fuel & oil, Hooker Harness. Radio & Xponder, based Kissimmee, \$10,000. Contact Matt Clark, UK 0044-191 4556892/101 5281715 or John Rossa, 407.396-7162. 994

Starduster SA100, TT 330, O-290, 125 hp Lyc. 185 SMOH, new radio, transponder, elt, upholstery, prop. Cleveland brakes, strobe, nav & landing lights, elec. start, fresh annual. Spare upper & lower wings, engine case, fuselage, parachute. \$13,500 406.961-3554 after 5 pm MT. 994

Starduster TOO. Completed 1989. 455 TT, 355 SMOH on 200 HP Lyc. IO360A1A, 355 since new on Hartzell CS aerobatic prop. King KT-76A Transponder/Mode C & KLX-135A Comm-/GPS/Intercom. Cleavelands, Hooker harnesses, Scott tail wheel, ACK ELT. Always. hangared Full inverted fuel and oil. A&P built. Stitts fabric. Open cockpit. \$28,000 (Firm). 318-949-3707 or email 71612.3110@compuserve.com. 992

FROM THE STARDUSTER WEB SITE

Starlet Sa 500 Fuselage. If you have one or know of one, please contact Ben. Telephone: 208-375-1813. -- Posted: 18 Aug 1999

Starduster For Sale. 160 hp Lycoming engine, less than 200 hours on engine. Constant speed Hartzell, New King 97, Apollo Loran, Heated, Ready to Go. \$35,000 CDN (approximately \$21,000 USD) Contact Jeremy Dann. Posted 17 Aug 1999

HERE NOW!

**THE MOST REVOLUTIONARY
AIRCRAFT COATINGS SINCE
CATALYZED PAINTS!**



**The first and only coatings
with the best qualities of the lead-
ing solvent-based paints
but without the risks.**

EPA/OSHA SAFE

No hazardous material shipping surcharges!

**GET FULL INFORMATION
CALL TOLL-FREE
1-877-534-7434**

*Sales, Applications and Technical Sup-
port:*

**Stolp Starduster Corp.
129 Chuck Yeager Way
Oroville, CA 95965
Fax: 530-534-7451**

Starduster Too - SA300 Project Wanted!! I am looking for a project that is in need of a new home. I have the plans but would like a project that someone may have pushed to the back of their hangar. Send me the details and specifics of the project you want to get rid of and let's see if we can work something out. I would be interested in anyone that may have completed sections and parts as well. Even if you only have the wings completed, or just the fuselage only, drop me a line. Contact Dave Honaker, Dallas TX. 972-716-2527 Posted: 7/28/99

1971 Starduster Too SA300 for Sale. Right Side..Left Side.. 517 TT, 70 TT SOH O-320A2B engine. Paint and fabric new in 1986. Beautiful navy colors done by Starduster, always hangared. New tires and brakes, Clevelands. Sigtronics inter-com, nav lites, beacon, wired for Icom A-22 radio. Cover for front cockpit. Excellent workmanship. Annual done 7-99. Asking \$28,500.00 O.B.O. T. Somrdem located Apple Valley CA Telephone: 760-242-1117. 7/26/99

Starduster II Wanted!! Looking for one in flying condition. Send details, history, price, and pics if available. Will travel in Western U.S. to see the right plane. Mike Carter. Posted: 7/3/99

Stolp Starduster for Sale!! Aircraft has a Lyc. O-320, 160 hp engine. 145 hours total on engine and airframe. KX175B nav-com. Fresh annual. New brakes and tail wheel. Flies great. I'm restoring a Navy N3N and need the \$ to complete this project. Contact Vernon Anderson, Wisconsin. Telephone: 920-787-5357. -- Posted: 5/27/99

Starduster SA100 project parts for sale!! Builder's data plate and airworthiness certificate, original aircraft log, 517 hours TT. Right upper wing complete, left upper wing spars and ribs with both wing tanks, right lower wing complete, left lower wing spar broken at tip. Extra set of lower wings with ailerons. Fuselage with tail feathers and control systems, cowling, fuel tank, Bodel-Adams wheels and brake system, Ceconite 102 cover kit, windshield, set of McWhite stainless flying wires. \$3,500. O-290-G engine and prop available also. Contact Talmadge Scott, Hernando, FL. 352-637-3511. -- Posted: 5/23/99

Starduster Too Plans for Sale!! Opened but never used. \$200.00 OBO. Contact John Lansden. Posted -- 4/26/99

SA100 Project for sale!! Welded fuselage, new spars, tail surface fixtures, some ribs. \$1,000.00. Contact Kevin Goehring, Lodi, CA (209)334-5064. -- Posted: 3/31/99

Starduster Too Project Wanted!! Contact Joe Antal, S.W. Ontario, Canada, 519-742-2196 (evenings). -- Posted 3/20/99

1981 Starduster Too for Sale!! 565 TT. Dual controls. O-320-G2A, 160 hp. Hartzell C/S, 131 hours SN Pistons, rings bearings, oil pump, full electrics, G Meter, 33 gallon, new KY97A, 604 Apollo. Cruise 130 mph. Always hangared. Built by AME. Enclosed roomy biplane with heat. \$42,500 CDN. Jeremy Dann, Canada. 902-538-8651. -- Posted 3/11/99

Starduster Too SA300. 1975 SA300 with O320 Lycoming. Approximately 250 hours on airframe and engine. Don't fly much in this cold climate in the winter. Vernon Anderson. -- Posted: 3/4/99

Bendix PS5C Carb Information. I have one of the first Starduster Too's built. I test flew it in August 1969 and have been enjoying it ever since! Lately I have been having problems starting it, but once warmed up no problem. I'm sure its the PS5C pressure carb and was wondering if anyone could give me a clue as to who I could contact or who would know what to adjust, etc. I wrote a Starduster Too Builder's Manual back in the 1970's. Did anyone ever see it? Contact Fred Meyer, based at Hollister Airport (35 miles south of San Jose, CA). 408-842-5418. -- Posted: 1/23/99

